



VE SERIES

Visual and electrical differential clogging indicators



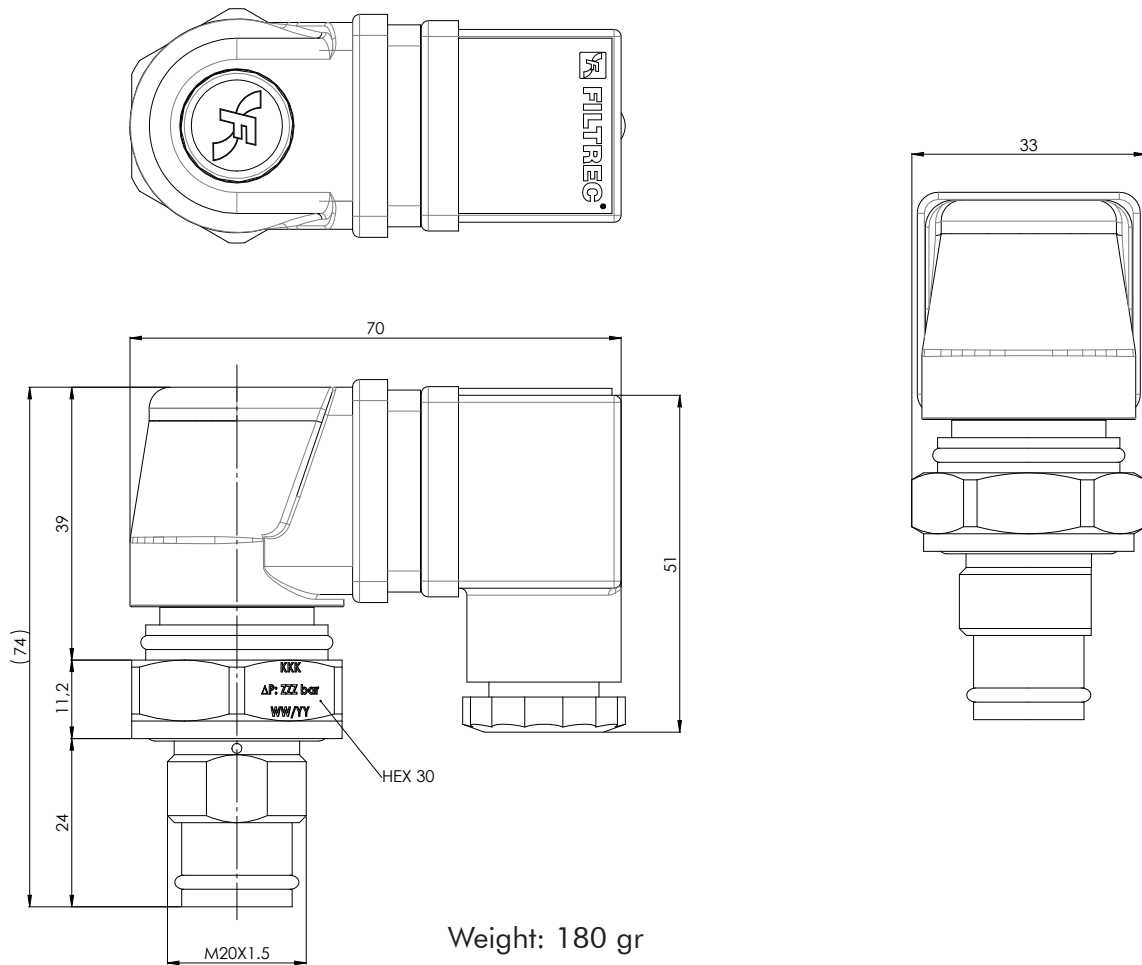

PRESSURE:	Max operating up to 420 bar
CONNECTION:	M20x1,5
MATERIALS:	Body: Brass Cover and connector: PA66 + G.F. Seal: FKM
SETTINGS ΔP :	2,7 bar \pm 10% 5,0 bar \pm 10% 8,0 bar \pm 10%
ELECTRICAL SPECS.:	Contact configuration SPDT
CONNECTOR TYPE:	according to DIN 43650 with cable gland PG09/PG11
DEGREE OF PROTECTION:	IP67 according to EN60529
OPERATING TEMPERATURE:	-30°C - +80°C
FLUID COMPATIBILITY:	Full with HH-HL-HM-HV-HETG-HEES-HFA HFB-HFC (acc. to ISO 6743/4). For use with other fluid please contact Filtrtec Customer Service (info@filtrtec.it).

OVERALL DIMENSIONS

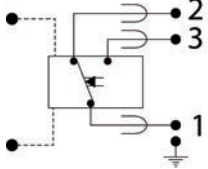

MECHANICAL CONDITION

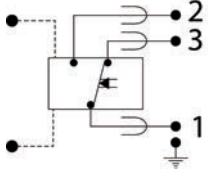
ΔP CONDITION	VISUAL CONDITION	ELECTRIC SYMBOL
$P+ - P- < \Delta P_{set}$: GREEN		
$P+ - P- \geq \Delta P_{set}$: RED		

ORDERING INFORMATION / DETAILS

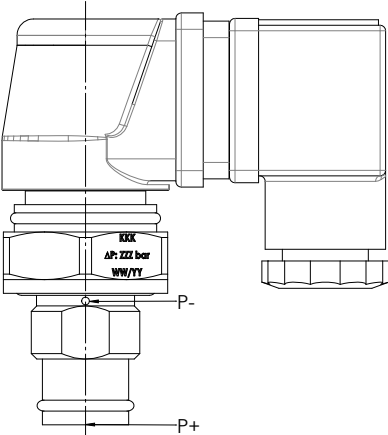
ORDER CODE	MODEL	VIEW	SETTING	ELECTRICAL SPECS.
04.006.00388	VEF2		2,7 bar	<ul style="list-style-type: none"> • Connector DIN 43650 • Max AC voltage: 250Vac • Max current: 1A resistive 0.3A inductive • Max DC voltage: 24Vdc • Max current: 3A resistive 1A inductive • Protection: IP67 EN60529
04.006.00389	VEF5		5,0 bar	
04.006.00390	VEF8		8,0 bar	

 50 / 90 Nm - See hydraulic filter catalogues

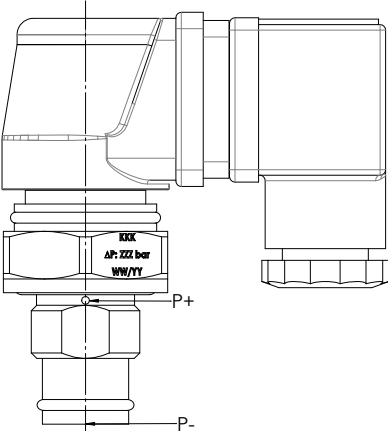
ORDER CODE	MODEL	VIEW	SETTING	ELECTRICAL SPECS.
04.006.00394	VEXF2		2,7 bar	<ul style="list-style-type: none"> • Connector DIN 43650 • Max AC voltage: 250Vac • Max current: 1A resistive 0.3A inductive • Max DC voltage: 24Vdc • Max current: 3A resistive 1A inductive • Protection: IP67 EN60529
04.006.00395	VEXF5		5,0 bar	
04.006.00396	VEXF8		8,0 bar	

 50 / 90 Nm - See hydraulic filter catalogues

INDICATOR SEAT

VE

VEX

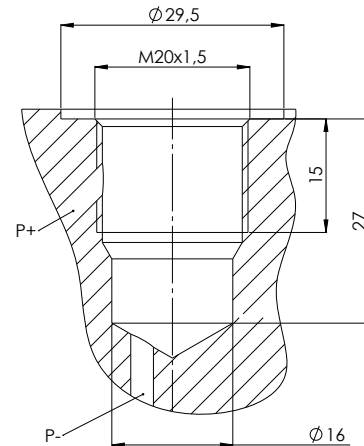
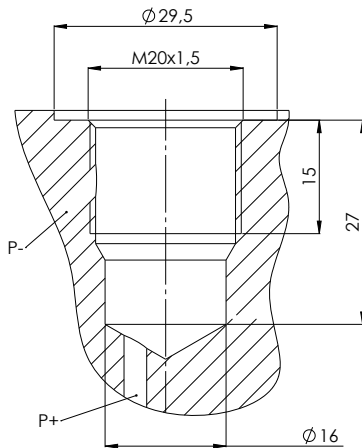

Dimensions and tolerances available on request

USER INFORMATION

The Differential indicator measures the Δp between upstream and downstream of the filter element, i.e. it is the ideal indicator for the in line applications.

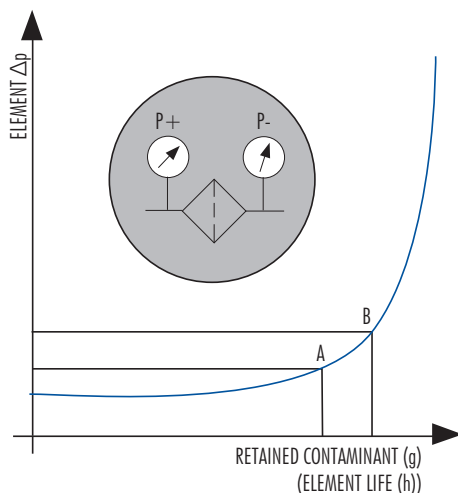

The **Pressure Drop** ($\Delta p =$ differential pressure) through the filter increases during the system operation due to the contaminant retained by the filter element.

The filter element must be replaced when the indicator shows an alarm and before the Δp reaches the by-pass set value (i.e. the set value A of the clogging indicator must always be lower than the set value B of the by-pass value).

WARNING: in **cold start** conditions a false alarm can be caused by higher oil viscosity due to low temperature; the indicator alarm must be considered at normal working temperature only.

OPTIONAL VERSION

Subject to MOQ our differential indicators type VE... can be supplied in special versions like ATEX or with different connectors.

Contact our Customer Service for further information.

APPLICATION

The following table shows the type of indicator available according to the filter used.

APPLICATION	FILTER CODE	INDICATOR MODEL					
		VEF2	VEF5	VEF8	VEXF2	VEXF5	VEXF8
IN LINE HIGH PRESSURE	F100	X	X	X			
	F280		X	X			
	F420		X	X			
	FD3					X	X
	FDM					X	X
	FH100	X	X	X			
	FH250		X	X			
	FH320		X	X			
	FH420-D1		X	X			
	FML320		X	X			
IN LINE MEDIUM PRESSURE	FLR				X	X	X
	FLRD				X	X	X
	F040	X	X	X			
RETURN	FCR7F2x	X					
	FCR7F3x	X					
SPIN-ON	FAH-A14x	X					
	FA5				X		
	FA4				X		

