



## FUH050-FUH100 SERIES

Transfer and filtration portable unit



### TECHNICAL SPECIFICATION

<b>MAIN:</b>	Flow Rate: FUH050: 50 l/min FUH100: 100 l/min Operating temperature: from 0 °C to +80°C Fluid viscosity range: 10-800cSt
<b>ELECTRIC:</b>	Voltage: 380/400 Vac 220/230 Vac (on request) Frequency: 50 - 60 Hz Power consumption: FUH050: 1,5Kw FUH100: 2,2Kw
<b>FRAME:</b>	Dimensions L, W, H[mm]: FUH050: 730X950X1110 FUH100: 730X950X1320
<b>DRY WEIGHT:</b>	FUH050: 148 Kg FUH100: 188 Kg
<b>MATERIALS:</b>	Base frame: Painted steel

### ELEMENT

tested according to ISO 11170, 2941, 2942, 2943, 3724, 3968, 16889, 16908, 23181

<b>FILTER MEDIA:</b>	Fiberglass: G01 - G03 - G06 - G10 G15 - G25 - G40 Water absorbent: GW03 - GW10 AW40
----------------------	--

<b>FLUID COMPATIBILITY:</b>	Full with HH-HL-HM-HV HETG-HEES (acc. to ISO 6743/4). For use with other fluid please contact Filtrec Customer Service (info@filtrec.it).
-----------------------------	---

The unit is supplied complete with an Instruction and Maintenance Manual available on our website [www.filtrec.com](http://www.filtrec.com) in the "Hydraulic Filter" section. The unit can be used by authorized operators who have read and understood all of its contents.

The FUH050 and FUH100 filtration units are certified

## OVERALL DIMENSIONS

### FUH050

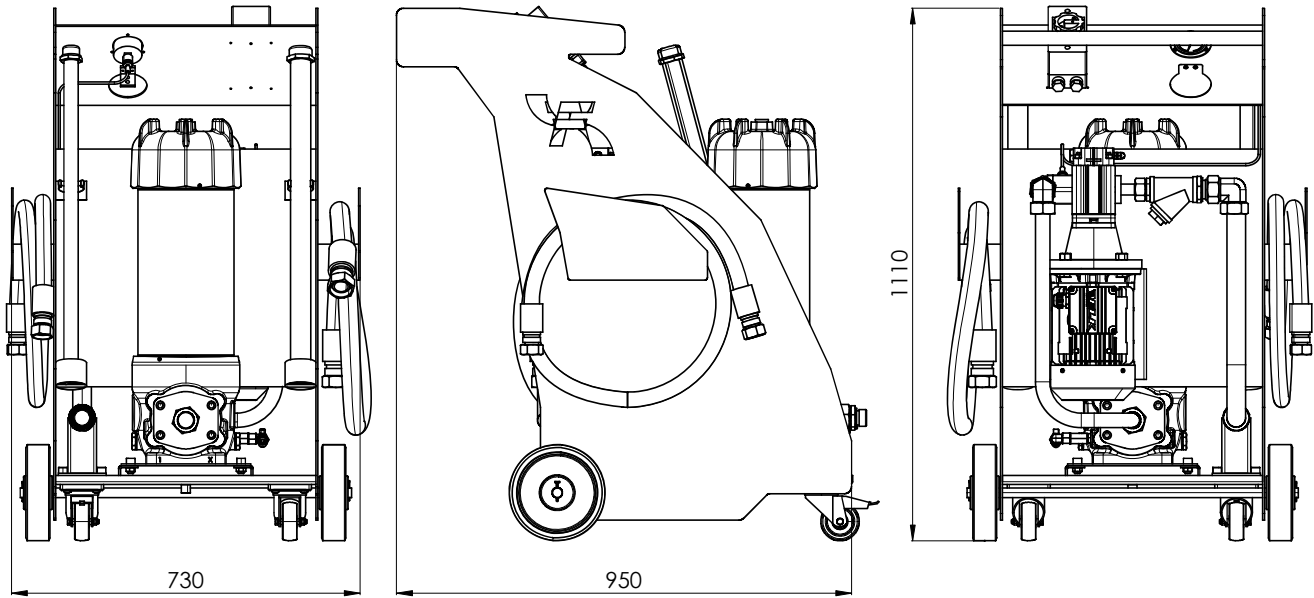

### FUH100

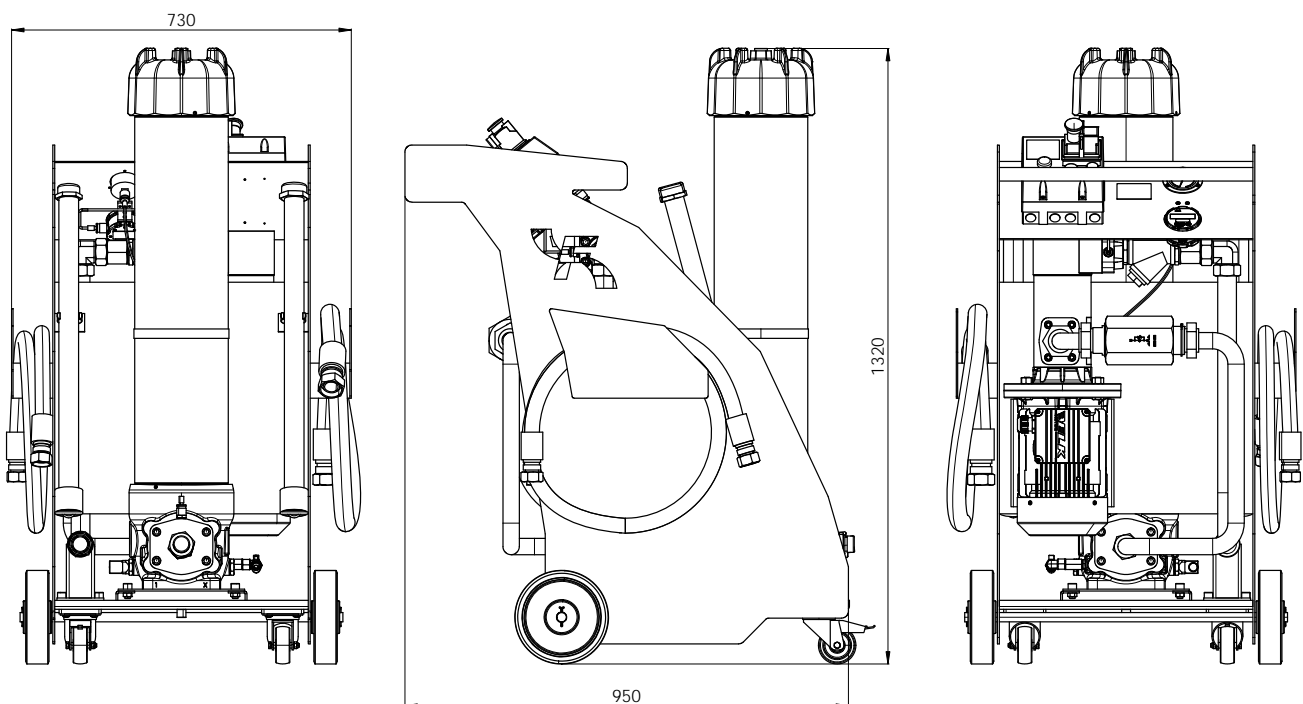

## HYDRAULIC DIAGRAM

### FUH050

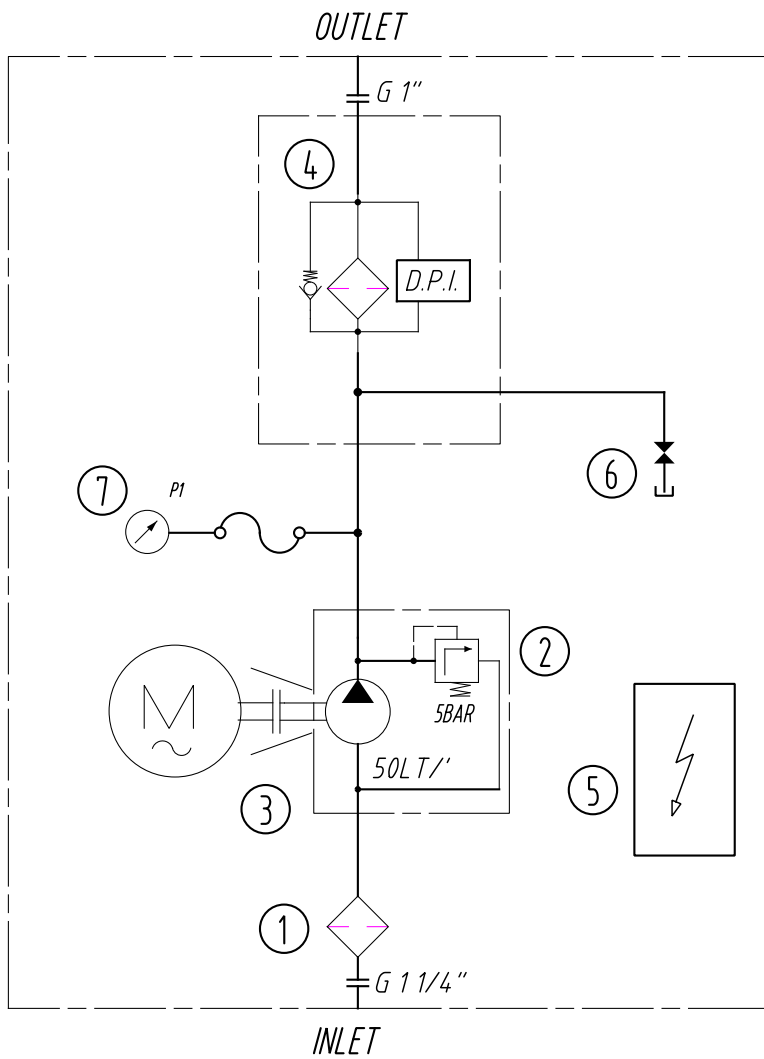

- 1- Suction filter "Y" 500  $\mu$ m
- 2- Gear pump + pressure relief valve 5 bar
- 3- Motor with pump coupling
- 4- Filter with visual clogging indicator
- 5- Control Panel
- 6- Sampling drain valve
- 7- Pressure gauge

Suction and delivery hoses are included but not connected

## HYDRAULIC DIAGRAM

### FUH100

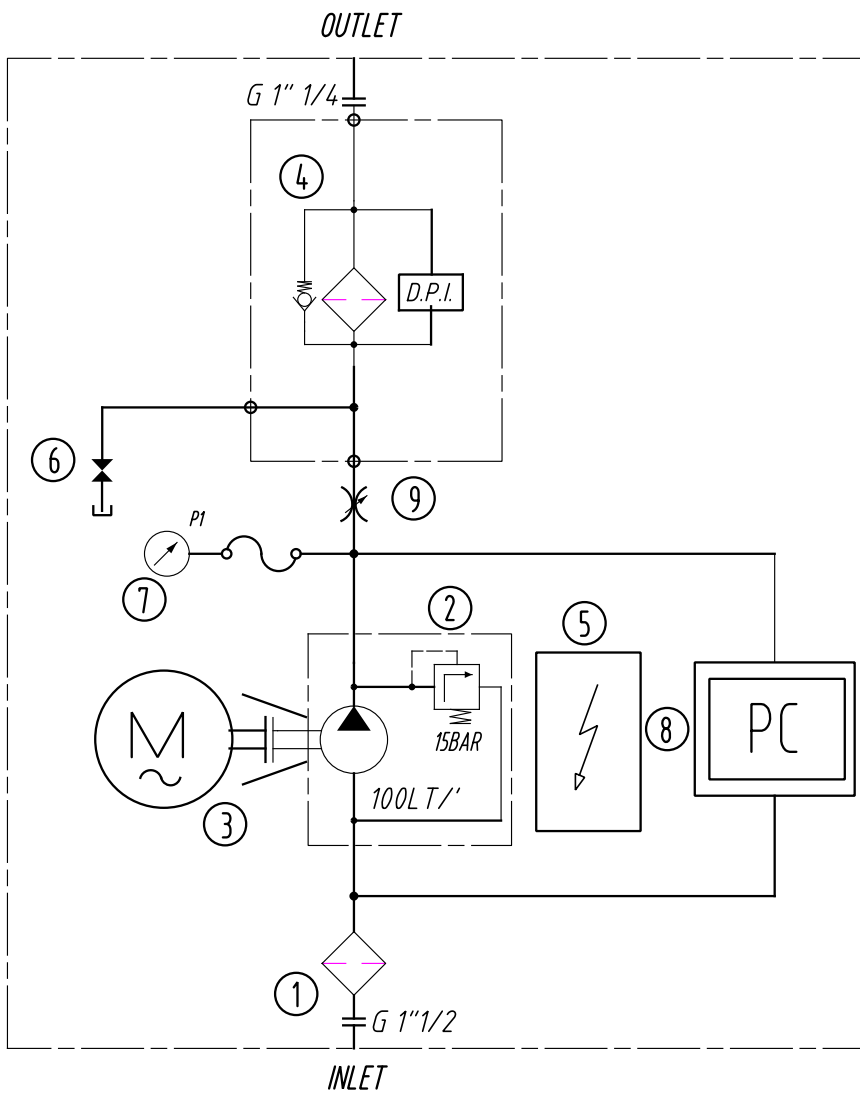

- 1- Suction filter "Y" 500  $\mu$ m
- 2- Screw pump + pressure relief valve 15 bar
- 3- Motor with pump coupling
- 4- Filter with visual-electric clogging indicator
- 5- Control Panel
- 6- Sampling drain valve
- 7- Pressure gauge
- 8- Particles Counter FMSC01S0
- 9- Flow restrictor valve for particles counter line

Suction and delivery hoses are included but not connected

## ORDERING INFORMATION FUH050

1.	2.	3.	4.	5.	6.	7.	8.
<b>FUH</b>	<b>050</b>	<b>T</b>	<b>G</b>	<b>2</b>	<b>B</b>	<b>S</b>	<b>0</b>
1. FILTER UNIT	FUH						
2. MODEL	050	flow rate 50 l/min					
3. ELECTRIC MOTOR	T	three phase electric motor, 380/400 Vac 50-60 Hz, 1,5 Kw					
	M	single phase electric motor, 220/230 Vac 50-60 Hz, 1,5 Kw (on request)					
4. PUMP SIZE	G	gear pump with + pressure relief valve 5 bar					
5. FILTER / ELEMENT SIZE	2	1 x U562 series					
6. SEAL	B	NBR					
7. VERSION	S	standard version					
8. OPTION	0	With visual clogging indicator, differential indicator model VX2 Support frame with drip tray Suction filter "Y" 500 µm Suction and delivery hoses + lance L=3m 3P+N+PE (N=not connected)+ industrial plug, L=2m Control panel with ON/OFF switch with safety release coil and emergency interlock push button					

## ORDERING INFORMATION FUH100

1.	2.	3.	4.	5.	6.	7.	8.
<b>FUH</b>	<b>100</b>	<b>T</b>	<b>S</b>	<b>4</b>	<b>B</b>	<b>C</b>	<b>1</b>
1. FILTER UNIT	FUH						
2. MODEL	100	flow rate 100 l/min					
3. ELECTRIC MOTOR	T	three phase electric motor, 380/400 Vac 50-60 Hz, 2,2 Kw					
	M	single phase electric motor, 220/230 Vac 50-60 Hz, 2,2 Kw (on request)					
4. PUMP SIZE	S	screw pump + pressure relief valve 15 bar					
5. FILTER / ELEMENT SIZE	4	1 x U564 series					
6. SEAL	B	NBR					
7. VERSION	C	with contamination monitor FMSC01S0 - particles counter					
8. OPTION	1	With visual/electric clogging indicator, differential indicator model VEXF2 Support frame with drip tray Suction filter "Y" 500 µm Suction and delivery hoses + lance L=3m 3P+N+PE (N=not connected)+ industrial plug, L=2m Control panel with ON/OFF switch with safety release coil and emergency interlock push button Control panel with indicator lights for: System ON – System OFF – Clogged Filter					

## ORDERING INFORMATION SPARE ELEMENTS

1.	2.	3.	4.	5.
<b>U5</b>	<b>64</b>	<b>G03</b>	<b>B</b>	<b>3</b>

1. FILTER ELEMENT SERIES	U5	
2. FILTER SIZE	62	
	64	
3. FILTER MEDIA	G01	glassfiber $\beta_{4\mu\text{m(c)}} > 1.000$
	G03	glassfiber $\beta_{5\mu\text{m(c)}} > 1.000$
	G06	glassfiber $\beta_{7\mu\text{m(c)}} > 1.000$
	G10	glassfiber $\beta_{12\mu\text{m(c)}} > 1.000$
	G15	glassfiber $\beta_{17\mu\text{m(c)}} > 1.000$
	G25	glassfiber $\beta_{22\mu\text{m(c)}} > 1.000$
	G40	glassfiber $\beta_{35\mu\text{m(c)}} > 1.000$
	GW03	glassfiber $\beta_{5\mu\text{m(c)}} > 1.000$ + water absorbent
	GW10	glassfiber $\beta_{12\mu\text{m(c)}} > 1.000$ + water absorbent
	AW40	water absorbent only (higher water retention capacity)
4. SEALS	B	NBR
5. BYPASS VALVE inbuilt into the filter element	0	no bypass
	3	3 bar

 FILTER ELEMENT - Preferred filter media - For the complete range of elements available, refer to the U56x series catalog.

## USER TIPS

The filter element must be replaced when:

1. the oil transfer is completed (if used as oil transfer unit).
2. the target cleanliness class is reached (when used as off line filtration unit); more filter elements could be necessary to reach it, depending on the oil volume to be cleaned and from the initial contamination level.
3. the clogging indicator shows.
4. a different filter media is required. We recommend a fine filtration; filter elements for water removal available when needed.

The unit is supplied complete with an Instruction and Maintenance Manual available on our website [www.filtrec.com](http://www.filtrec.com) in the "Hydraulic Filter" section. The unit can be used by authorized operators who have read and understood all of its contents.

