



FB2 SERIES

Air filters and filler breathers, with replaceable filter element



TECHNICAL SPECIFICATION

MATERIALS:	Housing: polyamide PA6+GF Basket : polyamide PA6+GF Gaskets : NBR
FILTER MEDIA:	Cellulose (air filtration 3 μ m) Glassfiber (air filtration 1 μ m)
TEMPERATURE RANGE:	-30°C to +100°C
FLUID COMPATIBILITY:	Full with HH-HL-HM-HV HETG-HEES (acc. to ISO 6743/4). For use with other fluid please contact Filtrec Customer Service (info@filtrec.it).

HYDRAULIC SYMBOL

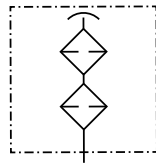

AIR BREATHING SIZING

Air Breathers play a crucial role as part of a hydraulic system's filtration mechanism. The amount of dust retained by an Air Breather depends on various factors, such as the average air dust concentration and the air flow passing through the breather in NI/min. The following table illustrates the typical average air dust concentrations found in real-life environments. Notably, these concentrations can vary significantly, thus impacting the service life of the Air Breather.

DUST CONCENTRATION (depends on application and environment)	$K_{op.cond}$
High level	7 ÷ 10
Medium level	3 ÷ 7
Low level	1 ÷ 3

Measuring the air flow poses a challenging task. Typically, this parameter can be estimated using the following equation:

$$Q_{air\ flow} = K_{op.cond} \times Q$$

Here, Q represents the flow rate of the hydraulic pump in l/min, and $K_{op.cond}$ is a multiplicative factor associated with the operating conditions. For instance, in ambient conditions with low dust concentration, $K_{op.cond}$ may range between 1 and 2, while in environments with high dust concentration, it could be in the range of 7 to 10. It is important to note that $K_{op.cond}$ is subject to substantial variability, which, in turn, introduces uncertainty in the service life of the Air Breather.



Filtrec's Air Breathers serve as a fundamental element in every hydraulic system.

It is essential to bear in mind that removing particles from a hydraulic system incurs significantly higher costs compared to excluding them in the first place.

Given this undeniable truth, it becomes evident that the advantages of utilizing our high-quality air breathers are substantial.

We highly recommend replacing the air breather with each service interval (or, at the very least, annually), matching the frequency of replacing the return fluid filters. Doing so ensures optimal performance and longevity of the hydraulic system.

OVERALL DIMENSIONS

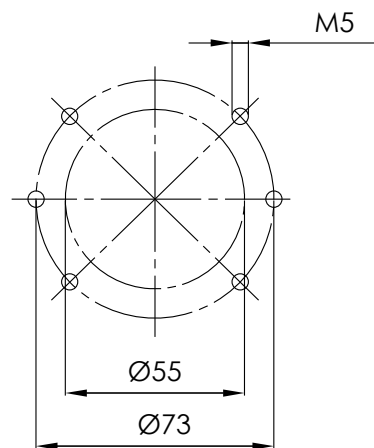
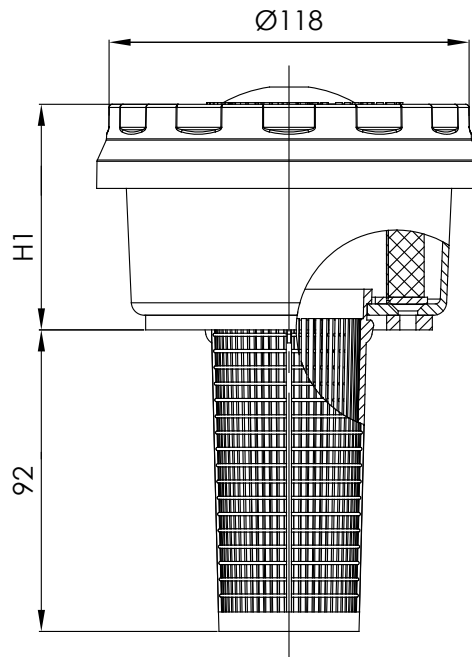

NOMINAL SIZE

CODE	H1	AIR FLOW RATE NI/min Dp 0,015 barg	
		C10	G10
FB250	46	1200	1400
FB251	74	1600	1800

ORDERING INFORMATION

1.	2.	3.	4.	5.
FB2	50	D2	C10	000
1. SERIES	FB2			
2. FILTER SIZE	50	length 1		
	51	length 2		
3. MOUNTING TYPE	D2	flange, DIN 24557/2		
4. FILTER MEDIA	000	without element		
	C10	cellulose (air filtration 3 μm)		
	G10	glassfiber (air filtration 1 μm)		
5. OPTIONS	000	no option		

ACCESSORIES

The accessories must be ordered separately

06.016.00283	SG515 Antisplash device
06.016.00548	BS125 Spacer support



ANTISPLASH DEVICE
SG515



SPACER SUPPORT
BS125

When the oil tank can be subjected to strong shocks or oscillations, the optional antisplash device (SG515) and the spacer support (BS125) prevents oil splashes from escaping and wetting the filter element.

SPARE ELEMENT

1.	2.	3.
B2	50	C10
1. SERIES	B2	
2. FILTER SIZE	50	length 1
	51	length 2
4. FILTER MEDIA	C10	cellulose (air filtration 3 μm)
	G10	glassfiber (air filtration 1 μm)

USER TIPS

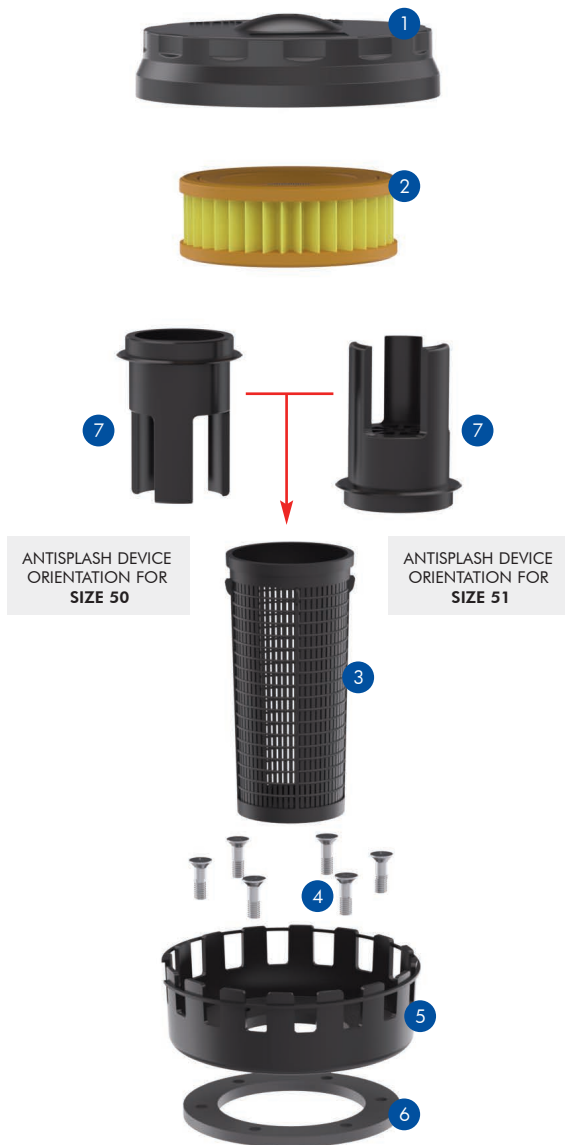

- 1 COVER
- 2 FILTER ELEMENT
- 3 BASKET
- 4 SCREWS
- 5 LOWER BODY
- 6 GASKET
- 7 ANTISPLASH

WARNING

- ⚠ Make sure that Personal Protective Equipment (PPE) is worn during installation and maintenance operation.

DISPOSAL OF FILTER ELEMENT

- ⚠ The used filter elements and the filter parts dirty of oil are classified as "Dangerous waste material": they must be disposed according to the local laws by authorized Companies.

INSTALLATION

1. Unscrew the cover (1).
2. Remove the filter element (2).
3. Insert the basket (3) in the lower body (5).
4. Place the gasket (6) on the tank; pay attention to keep the holes aligned.
5. Place the lower body (5) with the basket (3) on the gasket (6); pay attention to keep the holes aligned.
6. Attach the lower body (5) on the tank with the six screws. Screw until contact between screws and housing, then tighten for 2 more turns.
7. Fill the tank up to the set level.
8. Clean the lower body (5) from oil waste.
9. If the antisplash device (7) is provided, fit it in the basket (3). Antisplash orientation depends from the size (see image).
10. Fit the filter element (2) in the lower body (5).
11. Tighten the cover (1) on the lower body (5) applying 1/4 turn after the contact between the filter element (2) and the cover (1).

MAINTENANCE

- ⚠ 1. Before removing the cover (1) from the lower body (5), ensure that the system is switched off and there is no residual pressure in the filter.
- 2. Unscrew the cover (1).
- 3. Clean the lower body (5) from oil waste.
- 4. Fit the new filter element (2) in the lower body (5).
- 5. Tighten the cover (1) on the lower body (5) applying 1/4 turn after the contact between the filter element (2) and the cover (1).

