

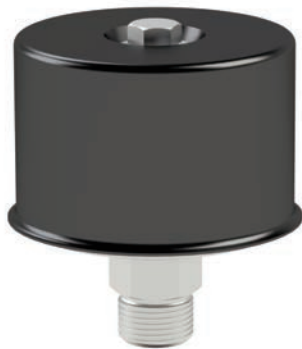

FB1 SERIES

Air breather filters, with replaceable filter element



TECHNICAL SPECIFICATION

MATERIALS:	Cover: painted steel Connection thread: steel zinc plated
FILTER MEDIA:	Cellulose (air filtration 3 μm)
TEMPERATURE RANGE:	-30° C to +100° C
FLUID COMPATIBILITY:	Full with HH-HL-HM-HV HETG-HEES (acc. to ISO 6743/4). For use with other fluid please contact Filtrec Customer Service (info@filtrec.it).

HYDRAULIC SYMBOL

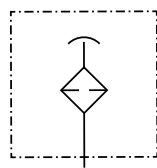

AIR BREATHING SIZING

Air Breathers play a crucial role as part of a hydraulic system's filtration mechanism. The amount of dust retained by an Air Breather depends on various factors, such as the average air dust concentration and the air flow passing through the breather in NI/min. The following table illustrates the typical average air dust concentrations found in real-life environments. Notably, these concentrations can vary significantly, thus impacting the service life of the Air Breather.

DUST CONCENTRATION (depends on application and environment)	$K_{op.cond}$
High level	7 ÷ 10
Medium level	3 ÷ 7
Low level	1 ÷ 3

Measuring the air flow poses a challenging task. Typically, this parameter can be estimated using the following equation:

$$Q_{air\ flow} = K_{op.cond} \times Q$$

Here, Q represents the flow rate of the hydraulic pump in l/min, and $K_{op.cond}$ is a multiplicative factor associated with the operating conditions. For instance, in ambient conditions with low dust concentration, $K_{op.cond}$ may range between 1 and 2, while in environments with high dust concentration, it could be in the range of 7 to 10. It is important to note that $K_{op.cond}$ is subject to substantial variability, which, in turn, introduces uncertainty in the service life of the Air Breather.



Filtrec's Air Breathers serve as a fundamental element in every hydraulic system.

It is essential to bear in mind that removing particles from a hydraulic system incurs significantly higher costs compared to excluding them in the first place.

Given this undeniable truth, it becomes evident that the advantages of utilizing our high-quality air breathers are substantial.

We highly recommend replacing the air breather with each service interval (or, at the very least, annually), matching the frequency of replacing the return fluid filters. Doing so ensures optimal performance and longevity of the hydraulic system.

OVERALL DIMENSIONS

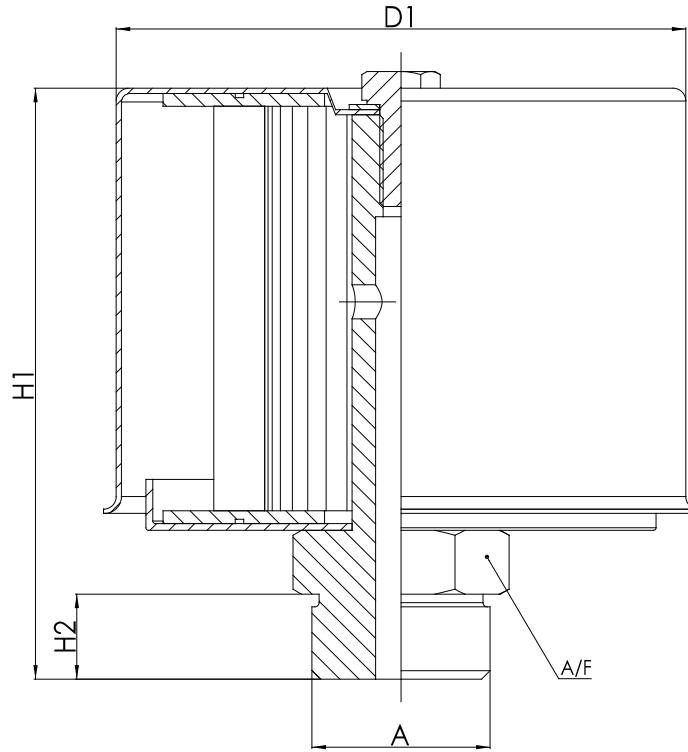

NOMINAL SIZE

CODE	A	D1	H1	H2	A/F	AIR FLOW RATE Nm ³ /min Dp 0,015 barg
FB110	G 1/4"-3/8"	48	54	9	14/19	250
FB120	G 1/2"-3/4"	67	69	10	22	350
FB130	G 1"	108	91	15	34	800

OVERALL DIMENSIONS

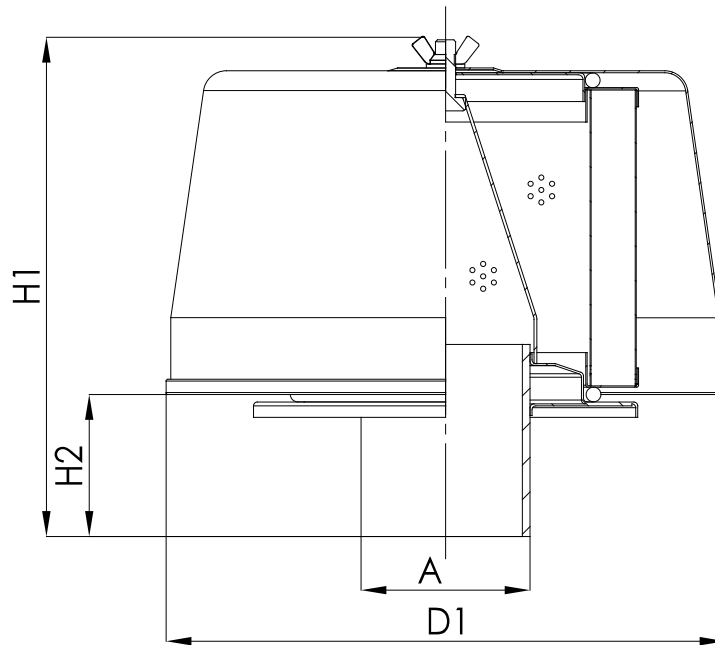

NOMINAL SIZE

CODE	A	D1	H1	H2	AIR FLOW RATE NI/min Dp 0,015 barg
FB140	G 1" G 1 1/4"	130	100	40 60	1200 2000
FB141	G 1 1/2" G 2"	130	130	45 60	2500 3300
FB150	G 2"	172	160	50	5000
FB160	G 2 1/2"	204		9000	
FB170	G 3"	290	190	60	15000
FB180	G 4"	336	240		25000

ORDERING INFORMATION

1.	2.	3.	4.
FB1	10	B2	C10
1. SERIES	FB1		
2. FILTER SIZE	10	cover Ø48	
	20	cover Ø67	
	30	cover Ø108	
	40	cover Ø130	
	41	cover Ø130	
	50	cover Ø172	
	60	cover Ø204	
	70	cover Ø290	
	80	cover Ø336	
3. CONNECTION	B1	G 1/4"	size 10
	B2	G 3/8"	
	B3	G 1/2"	size 20
	B4	G 3/4"	
	B5	G 1"	size 30-40
	B6	G 1 1/4"	size 40
	B7	G 1 1/2"	size 41
	B8	G 2"	size 41-50
	B9	G 2 1/2"	size 60
	B10	G 3"	size 70
	B12	G 4"	size 80
	4. FILTER MEDIA	C10	cellulose (air filtration 3 µm)

ORDERING INFORMATION

1.	2.	3.
B1	10	C10
1. SERIES	FB1	
2. FILTER SIZE	10	cover Ø48
	20	cover Ø67
	30	cover Ø108
	40	cover Ø130
	41	cover Ø130
	50	cover Ø172
	60	cover Ø204
	70	cover Ø290
	80	cover Ø336
3. FILTER MEDIA	C10	cellulose (air filtration 3 µm)

USER TIPS for size 10-20-30



- 1 SCREWS
- 2 WASHER
- 3 COVER
- 4 FILTER ELEMENT
- 5 MALE THREAD

WARNING

-  Make sure that Personal Protective Equipment (PPE) is worn during installation and maintenance operation.

DISPOSAL OF FILTER ELEMENT

-  The used filter elements and the filter parts dirty of oil are classified as "Dangerous waste material": they must be disposed according to the local laws by authorized Companies.

INSTALLATION

1. The air breather filters are mounted on the tank in a threaded seat (no burrs, sharp edges or dirt is admitted on the seat).
2. Add some lubricant on the male thread (5) and tighten until stop.
3. Refer to the tank manufacturer specifications for tighten torque.

MAINTENANCE

-  1. Before removing the top cover (3) from the housing, ensure that the system is switched off and there is no residual pressure in the system.
- 2. Unscrew the upper screw (1).
- 3. Remove the screw (1) and the washer (2).
- 4. Remove the cover (3).
- 5. Remove the clogged filter element (4).
- 6. Insert the new filter element.
- 7. Place the cover (3).
- 8. Fit the washer (2) and the screw (1) in the seat, applying a tightening torque of approx. 5Nm.

USER TIPS for size 40-41-50-60-70-80



- 1 LOCK NUT
- 2 WASHER
- 3 SCREW
- 4 COVER
- 5 O-RING
- 6 FILTER ELEMENT
- 7 MALE THREAD

WARNING

-  Make sure that Personal Protective Equipment (PPE) is worn during installation and maintenance operation.

DISPOSAL OF FILTER ELEMENT

-  The used filter elements and the filter parts dirty of oil are classified as "Dangerous waste material": they must be disposed according to the local laws by authorized Companies.

INSTALLATION

1. The air breather filters are mounted on the tank in a threaded seat (no burrs, sharp edges or dirt is admitted on the seat).
2. Add some lubricant on the male thread (7) and tighten until stop.
3. Refer to the tank manufacturer specifications for tighten torque.

MAINTENANCE

-  1. Before removing the top cover (4) from the housing, ensure that the system is switched off and there is no residual pressure in the system.
- 2. Unscrew the lock nut (1).
- 3. Remove the lock nut (1) and the washer (2).
- 4. Remove the screw (3) and the cover (4).
- 5. Remove the clogged filter element (6).
- 6. Check the O-rings (5) and replace them if necessary.
- 7. Insert the new filter element.
- 8. Place the cover (4).
- 9. Fit the lock nut (1), washer (2) and the screw (3) in the seat, tightening by hand (approx. 5Nm).

