



## F035 SERIES

In line medium pressure filters

Inline filters for operating pressure up to 30 bar, flow rate up to 400 l/min, suitable for use on suction, return or low pressure line.



<b>HOUSING</b>	tested according to NFPA T3.10.5.1, ISO 10771, ISO 3968
<b>PRESSURE:</b>	Max operating: 30 bar Burst: 120 bar
<b>CONNECTIONS:</b>	G 1 1/4"
<b>MATERIALS:</b>	Head: aluminium alloy Bowl: aluminium alloy Seal: NBR (FKM on request)
<b>BYPASS VALVE:</b>	Inbuilt in the filter element S version 0,25 bar 3 version 3 bar
<b>ELEMENT</b>	tested according to ISO 11170, 2941, 2942, 2943, 3724, 3968, 16889, 16908, 23181
<b>FILTER MEDIA:</b>	Inorganic microfiber: G01 - G03 - G06 - G10 G15 - G25 - G40 Paper: C10 - C25 Wire mesh: T60 - T125 - T250 Synthetic: M05 - M10 - M15
<b>COLLAPSE PRESSURE:</b>	10 bar
<b>TEMPERATURE RANGE:</b>	with NBR seal from -30 °C to +100 °C  with FKM seal (OPTION) from -25 °C to +120 °C
<b>FLUID COMPATIBILITY:</b>	Full with HH-HL-HM-HV HETG-HEES (acc. to ISO 6743/4). For use with other fluid please contact Filtrec Customer Service (info@filtrec.it).

## OVERALL DIMENSIONS

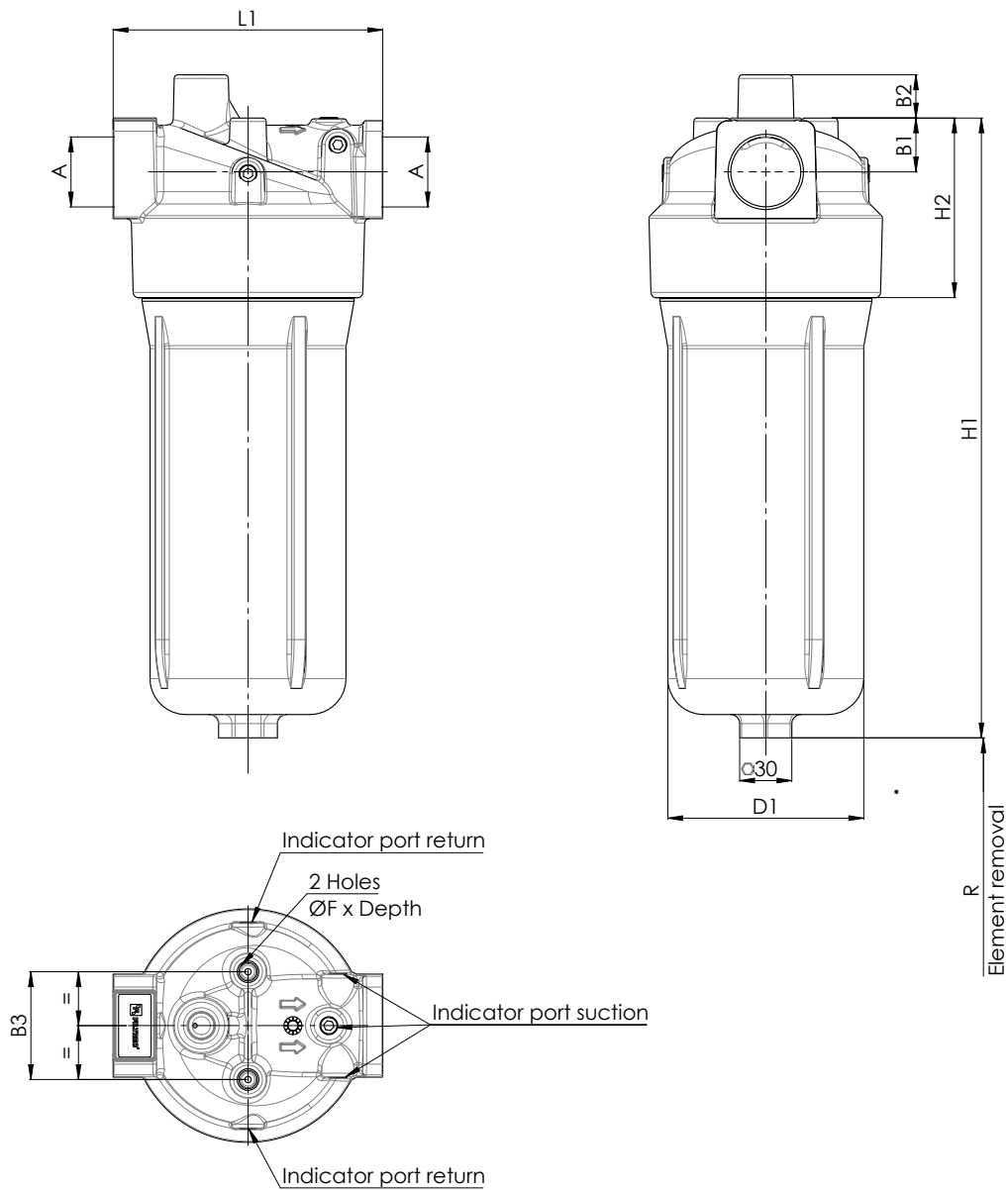

## NOMINAL SIZE

MODEL	A	B1	B2	B3	D1	F	H1	H2	L1	R	WEIGHT
F035-DMD0014							230				2,9 Kg
F035-DMD0029	G 1 1/4"	30	24	60	109	M12x18	345	100	150	130	3,9 Kg
F035-DMD0044							461				4,9 Kg

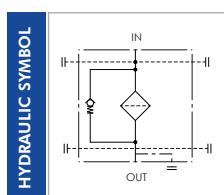

## ORDERING INFORMATION

	1.	2.	3.	4.	5.	6.	7.	8.	9.	10.	11.
	<b>F035</b>	<b>DMD</b>	<b>0014</b>	<b>G10</b>	<b>B3</b>	<b>B</b>	<b>B6</b>	<b>0</b>	<b>000</b>	<b>S</b>	<b>0</b>
SPARE ELEMENT		<b>DMD</b>	<b>0014</b>	<b>G10</b>	<b>B3</b>						

1. FILTER SERIES	F035		
2. FILTER ELEMENT SERIES	DMD		
3. FILTER SIZE	0014-0029-0044		
4. FILTER MEDIA	000	no element	
	G01	glassfiber $\beta_{4\mu\text{m(c)}} \geq 1.000$	
	G03	glassfiber $\beta_{5\mu\text{m(c)}} \geq 1.000$	
	G06	glassfiber $\beta_{7\mu\text{m(c)}} \geq 1.000$	for line/return
	G10	glassfiber $\beta_{12\mu\text{m(c)}} \geq 1.000$	
	G15	glassfiber $\beta_{17\mu\text{m(c)}} \geq 1.000$	
	G25	glassfiber $\beta_{22\mu\text{m(c)}} \geq 1.000$	
	G40	glassfiber $\beta_{35\mu\text{m(c)}} \geq 1.000$	for line/return/suction
	C10	cellulose $\beta_{10\mu\text{m(c)}} \geq 2$	
	C25	cellulose $\beta_{25\mu\text{m(c)}} \geq 2$	
	T60	wire mesh	for suction
	T125	wire mesh	
	T250	wire mesh	
	M05	synthetic $\beta_{10\mu\text{m(c)}} \geq 1.000$	
	M10	synthetic $\beta_{15\mu\text{m(c)}} \geq 1.000$	for line/return
	M15	synthetic $\beta_{20\mu\text{m(c)}} \geq 1.000$	
5. BYPASS VALVE	B0	no by-pass (empty housing)	
inbuilt in the element	BS	0,25 bar - suction	
	B3	3 bar - line/return	
6. HOUSING SEALS	B	NBR	
	V	FKM	
7. CONNECTIONS	B6	G 1 1/4"	
8. INDICATOR PORT OPTION	Y	5 x G 1/8" no.3 suction side, no.2 return side	
9. COMPULSORY FIELD	000	Filtrec standard	
10. CORROSION PROTECTION	S	standard	
11. OPTIONS	0	standard	

### ACCESSORIES

The accessories must be ordered separately

INDICATOR	MPC	pressure gauge 0-10 bar	
	MRC	pressure gauge 0-10 bar	for return
	PDC	pressure switch 2 bar SPDT	
	MPO	pressure gauge 0-16 bar	
	MPS	vacuum gauge 0 / -1 bar	for suction
	PDS	vacuum switch -0,2 bar SPDT	

## PRESSURE DROP ( $\Delta p$ ) INFORMATION FOR FILTER SIZING

The total Delta P through a filter assembly is given from Housing  $\Delta p$  + Element  $\Delta p$ .

This ideally should not exceed 1,0 bar and should never exceed 1/3 of the set value of the by-pass valve. N.B. All the reported data have been obtained at our laboratory, according to specification ISO3968 with mineral oil having 32 cSt viscosity and density 0,875 Kg/dm<sup>3</sup>.

### HOUSING PRESSURE DROP

The housing  $\Delta p$  is given by the curve of the considered model and port, in correspondence of the flow rate value.

#### F035DMD0014-0029-0044

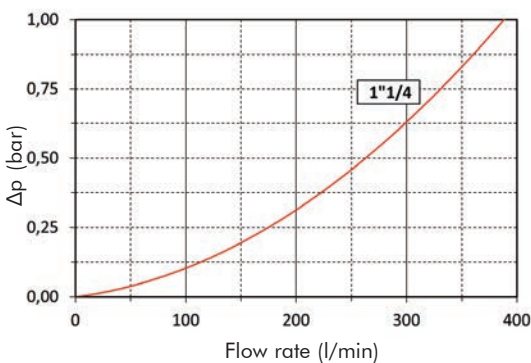

### ELEMENT PRESSURE DROP

The element  $\Delta p$  (bar) is given by the flow rate (l/min) multiplied by the factor in the table here below corresponding to the selected media and divided by 1000.

If the oil has a viscosity  $V_x$  different than 32 cSt a corrective factor  $V_x/32$  must be applied.

Example: 175 l/min with DMD0029G10B3 and oil viscosity 46 cSt:  $(175 \times 1,40)/1000 \times (46/32) = 0,35$  bar

	G01	G03	G06	G10	G15	G25	G40	C10	C25	T60	T125	T250	M05	M10	M15
<b>DMD0014</b>	13,19	9,45	5,56	3,09	2,25	1,61	0,89	1,59	0,80	0,30	0,29	0,28	1,68	1,64	1,60
<b>DMD0029</b>	6,22	4,48	2,75	1,40	1,03	0,75	0,40	0,73	0,39	0,21	0,20	0,19	0,78	0,76	0,74
<b>DMD0044</b>	3,99	2,84	1,82	1,00	0,78	0,69	0,33	0,60	0,32	0,17	0,16	0,15	0,64	0,60	0,50

### EXAMPLE OF TOTAL $\Delta p$ CALCULATION

F035DMD0014G10B3B60000S0 with 60 l/min and oil 46 cSt:

Housing  $\Delta p$  0,25 bar + element  $\Delta p$  0,35 bar  $(175 \times 1,40/1000 \times 46/32)$  = total assembly  $\Delta p$  0,60 bar

## BYPASS VALVE PRESSURE DROP

The bypass valve  $\Delta p$  is given by the curve of the considered model and setting, in correspondence of the flow rate value.

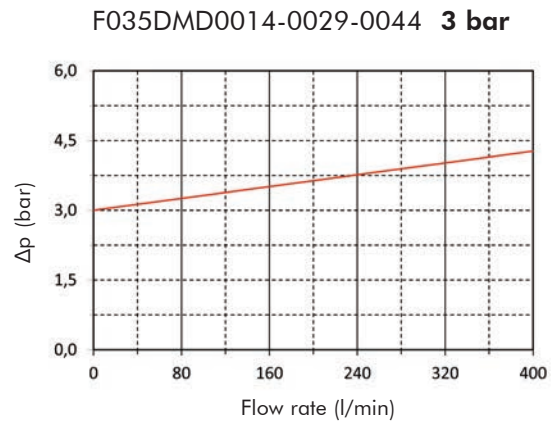
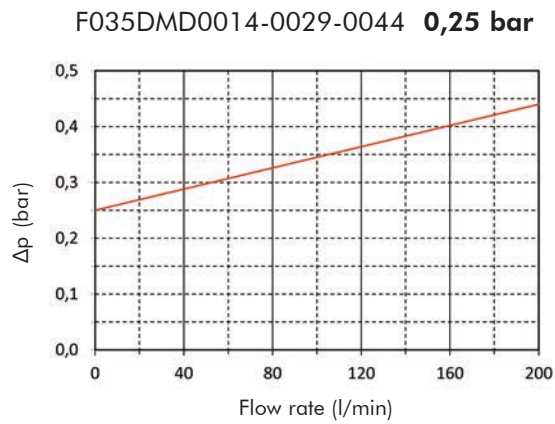

N.B. All the reported data have been obtained at our laboratory, according to specification ISO3968 with mineral oil having 32 cSt viscosity and density 0,875 Kg/dm<sup>3</sup>.

## USER TIPS



- 1 FILTER HEAD
- 2 FIXING HOLES
- 3 FILTER ELEMENT
- 4 FILTER BOWL
- 5 SEAL KIT
- 6 IDENTIFICATION LABEL
- 7 INDICATOR PORTS

### INDICATOR TIGHTENING TORQUE

10 Nm

### BOWL TIGHTENING TORQUE

Screw up filtre bowl till end

### SPARE SEAL KIT PART NUMBER (5)

	NBR	FKM
F035 DMD0014/29/44	06.021.00129	06.021.00130



### WARNING

-  Make sure that Personal Protective Equipment (PPE) is worn during installation and maintenance operation.

### DISPOSAL OF FILTER ELEMENT

-  The used filter elements and the filter parts dirty of oil are classified as "Dangerous waste material": they must be disposed according to the local laws by authorized Companies.



## INSTALLATION

-  1. The IN and OUT ports must be connected to the hoses in the correct flow direction an arrow shows on the filter head (1).
- 2. The filter housing should be preferably mounted with the bowl (4) downward.
- 3. Secure to the frame the filter head (1) using the threaded fixing holes (2).
- 4. Verify that no tension is present on the filter after mounting.
- 5. Enough space must be available for filter element replacement.
-  6. Never run the system with no filter element fitted.
- 7. Keep in stock a spare FILTREC filter element for timely replacement when required.
- 8. Filter housing should be earthed

## OPERATION

-  1. The filter must work within the operating conditions of pressure, temperature and compatibility given in the first page of this data sheet.
- 2. The filter element must be replaced as soon as the clogging indicator signals at working temperature (in cold start conditions, oil temperature lower than 30°C, a false alarm can be given due to oil viscosity).
- 3. If no clogging indicator is mounted, replace the element according to the system manufacturer's recommendations.

## MAINTENANCE

-  1. Make sure that the system is switched off and there is no residual pressure in the filter.
- 2. Unscrew the bowl (4) by turning it anti-clockwise and remove it.
- 3. Remove the dirty element (3).
- 4. Fit a new FILTREC element (3), verifying the part number, particularly concerning the micron rating; open its plastic protection on the open end side and insert it onto the spigot in the filter head, then remove completely the plastic protection.
- 5. Clean carefully the bowl; check the O-rings (5) conditions and replace if necessary.
- 6. Lubricate the bowl's thread (4) and screw it by hand in the filter head (1) by turning it clockwise.
- 7. Screw in the bowl to stop.
-  8. The used filter elements cannot be cleaned and re-used.

