



FUH015 SERIES

Transfer and filtration portable unit



TECHNICAL SPECIFICATION

MAIN:	Flow Rate: 15 l/min Operating temperature: from 0 °C to +80 °C Fluid viscosity range: 10-220 cSt
ELECTRIC:	Voltage: 230 V Frequency: 50 - 60 Hz Power consumption: 0.25 kW
FRAME:	Dimensions L, W, H [mm]: 290 x 368 x 533 mm Dry Weight: 16 kg
MATERIALS:	Base frame: Painted steel

ELEMENT

	tested according to ISO 11170, 2941, 2942, 2943, 3724, 3968, 16889, 16908, 23181
FILTER MEDIA:	Fiberglass: G03 - G06 - G10 - G25 Fiberglass with water removal: GW03 - GW06 - GW10 - GW25 Paper: C25 Paper with water removal: CW25
FLUID COMPATIBILITY:	Full with HH-HL-HM-HV HETG-HEES (acc. to ISO 6743/4). For use with other fluid please contact Filtrec Customer Service (info@filtrec.it).

The unit is supplied complete with an Instruction and Maintenance Manual available on our website www.filtrec.com in the "Hydraulic Filter" section. The unit can be used by authorized operators who have read and understood all of its contents.

The FUH015 filtration unit is certified

OVERALL DIMENSIONS

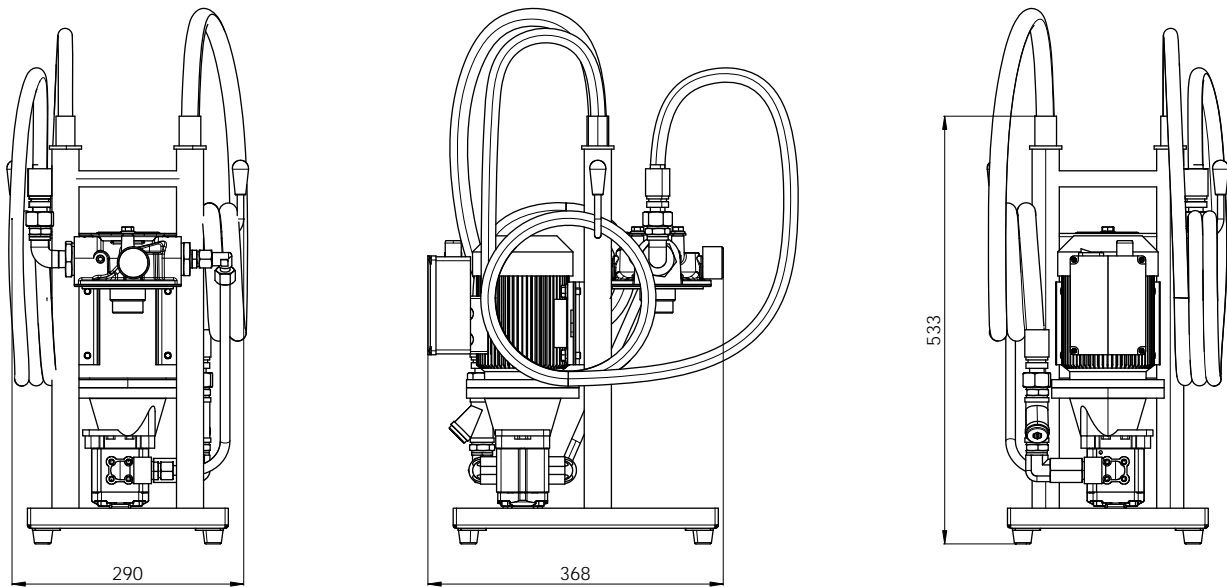

The filter unit comes with filter head installed. The spin-on elements should be ordered separately. You can install either 1 x A120 - or - 1 x A121 - or- 1 x A150.

HYDRAULIC DIAGRAM

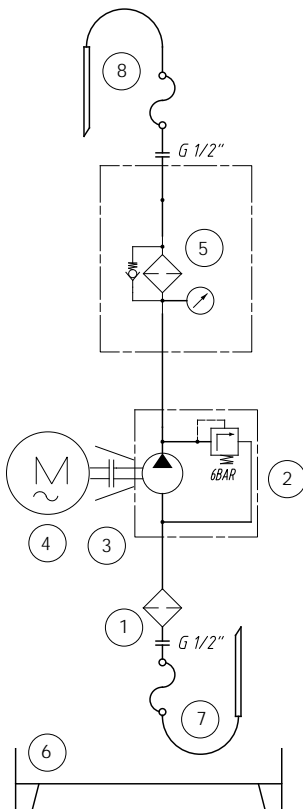

- 1 - Suction filter "Y" 500 μ m
- 2 - Gear pump with + pressure relief valve 6bar
- 3 - Motor - pump coupling
- 4 - Motor
- 5 - Filter
- 6 - Base frame
- 7 - Suction pipes in armorvin + lance L=2m
- 8 - Delivery pipes in armorvin + lance L=2m

ORDERING INFORMATION FUH015

1.	2.	3.	4.	5.	6.	7.	8.
FUH	015	M	G	0	B	S	0
1. FILTER UNIT	FUH						
2. MODEL	015	flow rate 15 l/min					
3. ELECTRIC MOTOR	M	single phase electric motor, 230V 50-60Hz 0,25 KW					
4. PUMP SIZE	G	gear pump with + pressure relief valve 6bar					
5. FILTER / ELEMENT SIZE	0	1 x A120 - or - 1 x A121 - or- 1 x A150					
6. SEAL	B	NBR					
7. VERSION	S	standard version					
8. OPTION	0	standard option *					

- (*)
- With cloggin indicator, pressure gauge model MPB
 - Suction filter "Y" 500 µm
 - Support frame with drip tray
 - Suction and delivery pipes in armorvin + lance L=2m
 - 2P+T industrial plug, L=2m

ORDERING INFORMATION SPARE ELEMENTS

1.	2.	3.	
A1	20	G10	
1. FILTER ELEMENT SERIES	A1		
2. FILTER SIZE	20-21	connection threads G 1 1/4"	
	50	connection threads 1 1/2"-16 UN	
3. FILTER MEDIA	G10	glassfiber $\beta_{12\mu m(c)} > 1.000$	AVAILABLE FILTER MEDIA FOR A120-A121
	G25	glassfiber $\beta_{22\mu m(c)} > 1.000$	
	C25	paper $\beta_{25\mu m(c)} > 2$	
	CW25	paper $\beta_{25\mu m(c)} > 2$ + water absorbent	
	G03	glassfiber $\beta_{5\mu m(c)} > 1.000$	AVAILABLE FILTER MEDIA FOR A150
	G06	glassfiber $\beta_{7\mu m(c)} > 1.000$	
	G10	glassfiber $\beta_{12\mu m(c)} > 1.000$	
	G25	glassfiber $\beta_{22\mu m(c)} > 1.000$	
	GW03	glassfiber $\beta_{5\mu m(c)} > 1.000$ + water absorbent	
	GW06	glassfiber $\beta_{7\mu m(c)} > 1.000$ + water absorbent	
	GW10	glassfiber $\beta_{12\mu m(c)} > 1.000$ + water absorbent	
	GW25	glassfiber $\beta_{22\mu m(c)} > 1.000$ + water absorbent	
	C25	paper $\beta_{25\mu m(c)} > 2$	
	CW25	paper $\beta_{25\mu m(c)} > 2$ + water absorbent	

FILTER ELEMENT - Preferred models - For the complete range of elements available, refer to the FA1 series catalog for size 20 and 21, and catalog FAH-A150 for size 50.

OVERALL DIMENSIONS FILTER ELEMENT

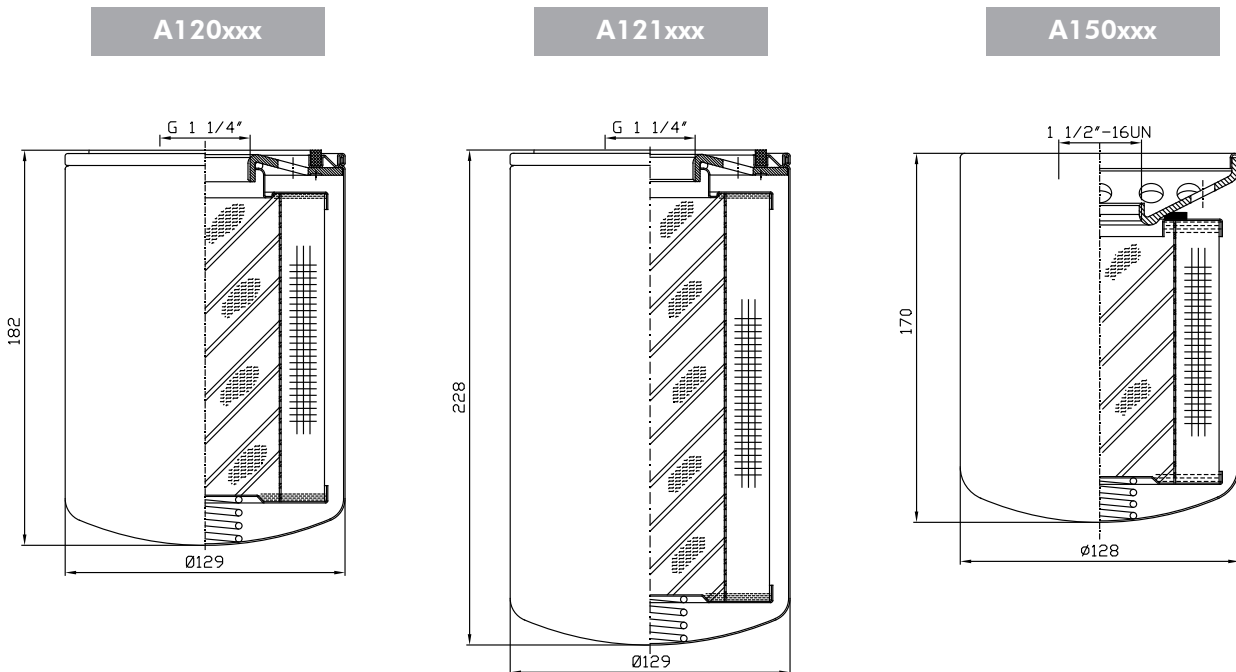

USER TIPS

The filter element must be replaced when:

1. the oil transfer is completed (if used as oil transfer unit).
2. the target cleanliness class is reached (when used as off line filtration unit); more filter elements could be necessary to reach it, depending on the oil volume to be cleaned and from the initial contamination level.
3. the clogging indicator shows.
4. a different filter media is required. We recommend a fine filtration; filter elements for water removal available when needed.

The unit is supplied complete with an Instruction and Maintenance Manual available on our website www.filtrec.com in the "Hydraulic Filter" section. The unit can be used by authorized operators who have read and understood all of its contents.

