



FRM SERIES

Tank top return filters

The FRM filters are available with various configurations:

- with 3 or 4 tank mounting holes
- with supplementary inlet ports
- flow rate up to 500 l/min
- with quick service cover



HOUSING	tested according to NFPA T3.10.5.1*, ISO 10771*, ISO 3968
PRESSURE:	Max operating: 10 bar
CONNECTIONS:	G 1 1/4" - G 3/4" - G 1" G 1 1/2" - G 1" + 1 1/4" SAE 3000 FLANGE M
MATERIALS:	Head: aluminium alloy Bowl: PA6 reinforced Seal: NBR (FKM on request)
BYPASS VALVE:	Inbuilt in the filter element C version 3 bar B version 1,7 bar
ELEMENT	tested according to ISO 11170, 2941, 2942, 2943, 3724, 3968, 16889, 16908, 23181
FILTER MEDIA:	Inorganic microfiber G03 - G06 - G10 - G15 - G25 - G40 Paper: C10 - C25 Wire mesh: T60 Synthetic: M05 - M10 - M15
COLLAPSE PRESSURE:	10 bar
TEMPERATURE RANGE:	-30°C + 100°C
FLUID COMPATIBILITY:	Full with HH-HL-HM-HV HETG-HEES (acc. to ISO 6743/4). For use with other fluid please contact Filtrec Customer Service (info@filtrec.it).

* as reference method only for verifying the pressure fatigue resistance and establishing the burst pressure ratings.

OVERALL DIMENSIONS FRM 40 43 45 B6B4B5

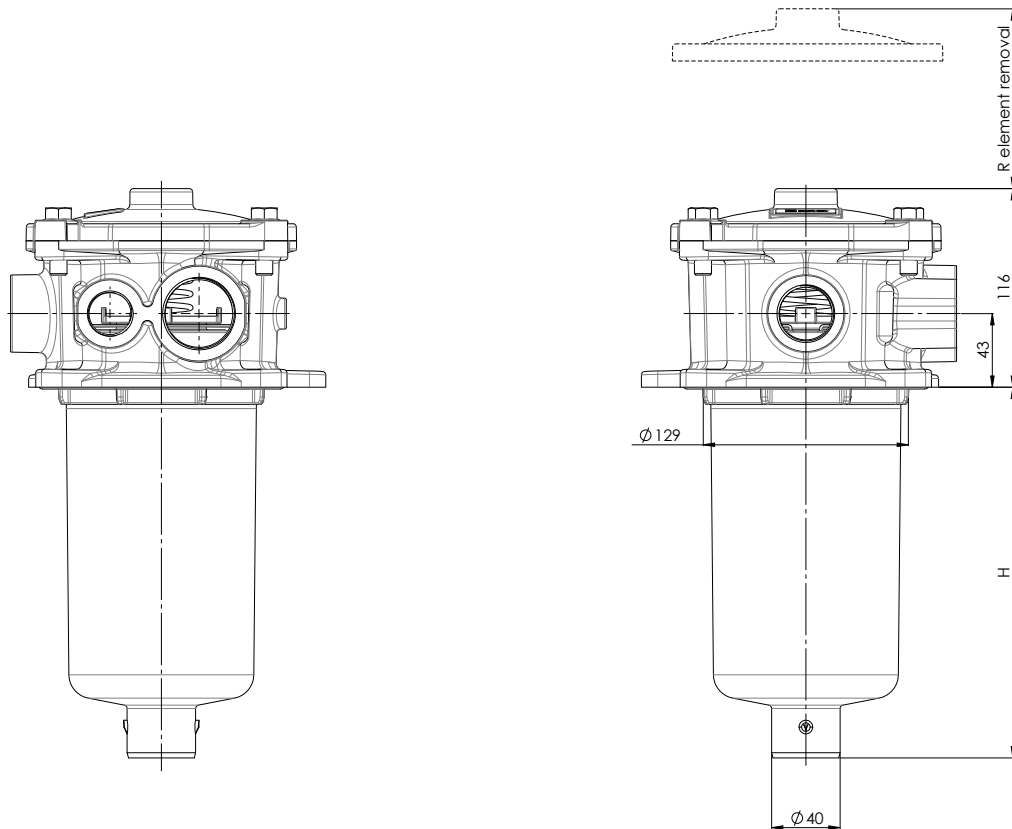

TANK MOUNTING PATTERN

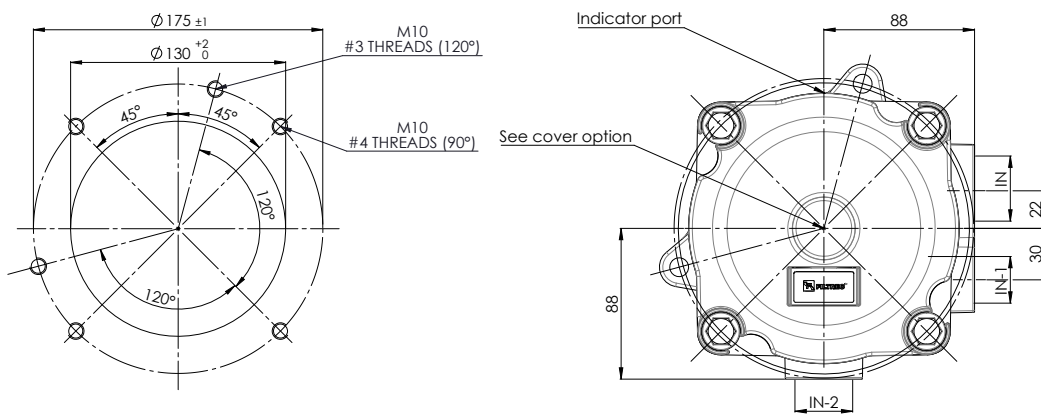

NOMINAL SIZE

MODEL	IN	IN-1	IN-2	H	R	WEIGHT
FRM-R1-40-B6B4B5				217	300	2,1 Kg
FRM-R1-43-B6B4B5	G 1 1/4"	G 3/4"	G 1"	263	350	2,2 Kg
FRM-R1-45-B6B4B5				430	520	2,4 Kg

HYDRAULIC SYMBOL

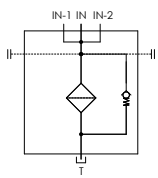

OVERAL DIMENSIONS FRM 40 43 45 B7B5F6M

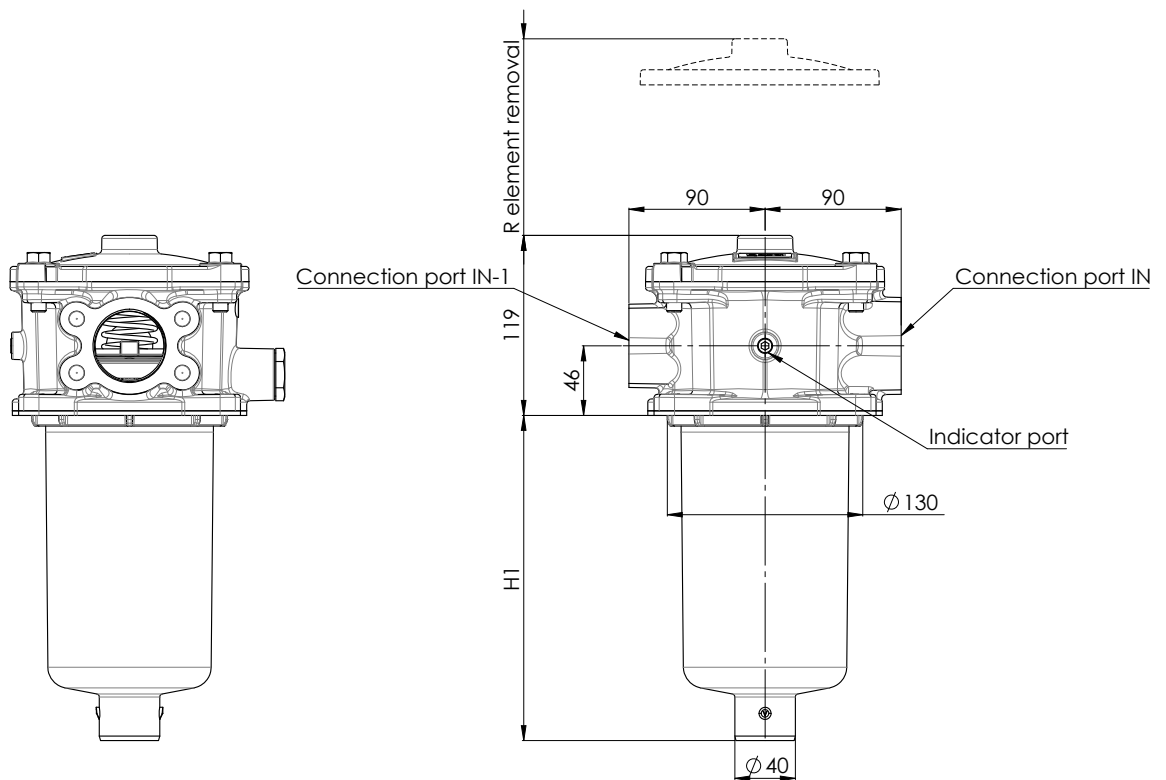

TANK MOUNTING PATTERN

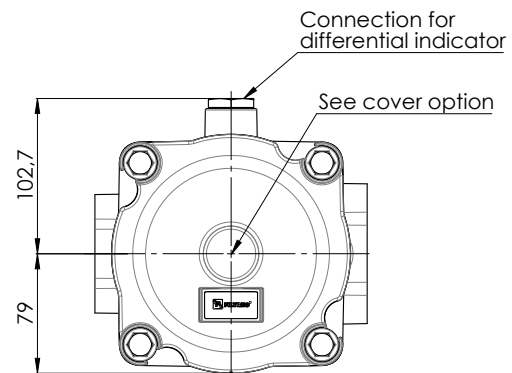
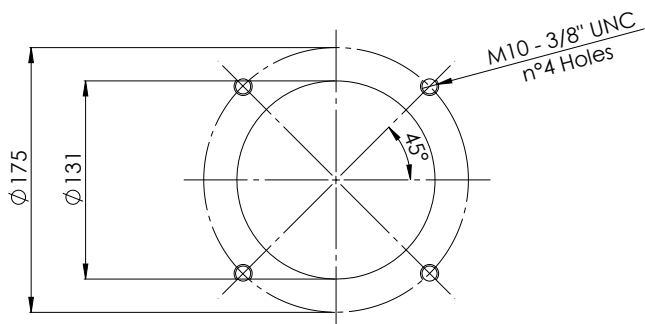

NOMINAL SIZE

MODEL	IN	IN-1	H1	R	WEIGHT
FRM-R1-40-B7B5F6M	G 1 1/2"	G 1" + 1 1/4" SAE 3000 M	215	300	3,5 Kg
FRM-R1-43-B7B5F6M			261	350	3,65 Kg
FRM-R1-45-B7B5F6M			428	520	4,25 Kg

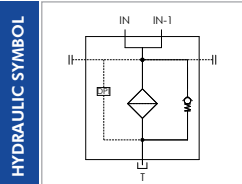

ORDERING INFORMATION

	1.	2.	3.	4.	5.	6.	7.	8.	9.	10.	11.	12.
	FRM	R1	43	G10	C	B	B6B4B5	0	T	000	S	0
SPARE ELEMENT	R1	43	G10	C								

1. FILTER SERIES	FRM	
2. FILTER ELEMENT SERIES	R1	
3. FILTER SIZE	40	
	43	
	45	
4. FILTER MEDIA	000	no element
	G03	glassfiber $\beta_{5\mu m(c)} \geq 1.000$
	G06	glassfiber $\beta_{7\mu m(c)} \geq 1.000$
	G10	glassfiber $\beta_{12\mu m(c)} \geq 1.000$
	G15	glassfiber $\beta_{17\mu m(c)} \geq 1.000$
	G25	glassfiber $\beta_{22\mu m(c)} \geq 1.000$
	G40	glassfiber $\beta_{35\mu m(c)} \geq 1.000$
	C10	paper $\beta_{10\mu m(c)} \geq 2$
	C25	paper $\beta_{25\mu m(c)} \geq 2$
	T60	wire mesh $60 \mu m$
	M05	synthetic $\beta_{10\mu m(c)} \geq 1.000$
	M10	synthetic $\beta_{15\mu m(c)} \geq 1.000$
	M15	synthetic $\beta_{20\mu m(c)} \geq 1.000$
5. BYPASS VALVE	C	3 bar
Inbuilt into the filter element	B	1,7 bar
6. SEALS	*B	NBR
*omitted for spare element	V	FKM
7. HEAD CONFIGURATION	B6B4B5	(IN) G 1 1/4" - (IN-1) G 3/4" - (IN-2) G 1"
	B7B5F6M	(IN) G 1 1/2" - (IN-1) G 1" + 1 1/4" SAE 3000 FLANGE M
8. COVER OPTION	0	without
	T	with filling plug 3/4" on top cover (on request)
	C	1/8" on top cover (plugged) (on request)
9. INDICATOR PORT OPTION	T	indicator ports with metal plug
	P	1/8" port with metal plug+differential port with plastic plug - only for head config. B7B5F6M
10. COMPULSORY FIELD	000	Filtrec standard
11. CORROSION PROTECTION	S	standard
12. OPTIONS	0	no option

ORDERING INFORMATION

ACCESSORIES

The accessories must be ordered separately

INDICATOR

The accessories must be ordered separately
(F) digit for FKM seal option
LC24=Led connector (see clogging indicators catalogue)
*only for B7B5F6M

MPB	press. gauge rear connection	
MRB	press. gauge radial connection	with "B" bypass option
PDB	pressure switch	
MPC	press. gauge rear connection	
MRC	press. gauge radial connection	
PDC	pressure switch	with "C" bypass option
*V02 (VF2)	differential visual 2,7 bar	
*E02 (EF2)	differential electric 2,7 bar	
*VEF2	differential visual electric 2,7 bar	
LC24	LED connector for PDB / PDC / E02	

EXTENSION TUBE

ET2250	extension tube 250 mm long
ET2500	extension tube 500 mm long

CONNECTION TUBE

CT2250	connection tube 250 mm long
--------	-----------------------------

DIFFUSER

DF040	diffuser Ø 40 mm
-------	------------------

PRESSURE DROP (Δp) INFORMATION FOR FILTER SIZING

The total Delta P through a filter assembly is given from Housing Δp + Element Δp .
The max recommended total Δp for return filters is 0,4 – 0,6 bar with clean element.

N.B. All the reported data have been obtained at our laboratory, according to specification ISO3968 with mineral oil having 32 cSt viscosity at 40°C and density 0,875 kg/dm³.

HOUSING PRESSURE DROP

The housing Δp is given by the curve of the considered model and port, in correspondence of the flow rate value.

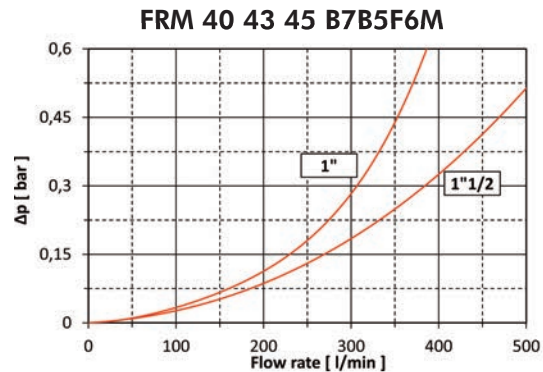
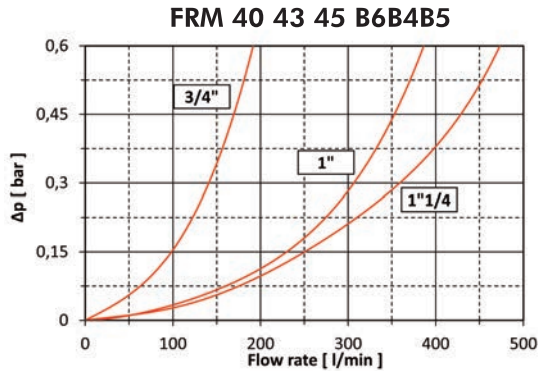

ELEMENT PRESSURE DROP

The element Δp (bar) is given by the flow rate (l/min) multiplied by the factor in the table here below corresponding to the selected media and divided by 1000.

If the oil has a viscosity V_x different than 32 cSt a corrective factor $V_x/32$ must be applied.

Example: 200 l/min with R143G10C and oil viscosity 46 cSt: $(200 \times 1,21)/1000 \times (46/32) = 0,35$ bar

	G03	G06	G10	G15	G25	G40	C10	C25	T60	M05	M10	M15
R140	3,59	2,43	1,31	1,25	1,10	0,43	0,85	0,39	0,22	0,95	0,82	0,62
R143	3,33	2,25	1,21	1,15	1,00	0,39	0,83	0,35	0,20	0,88	0,75	0,57
R145	2,15	1,35	0,55	0,52	0,50	0,17	0,42	0,22	0,10	0,52	0,44	0,32

EXAMPLE OF TOTAL Δp CALCULATION

FRMR143G10CBB6B4B50T000S0 with **200** l/min and oil **46** cSt (for port 1" 1/4):

Housing Δp 0,10 bar + element Δp 0,35 bar $(200 \times 1,21)/1000 \times (46/32) =$ total assembly Δp 0,45 bar

BYPASS VALVE PRESSURE DROP

The bypass valve Δp is given by the curve of the considered model and setting, in correspondence of the flow rate value.

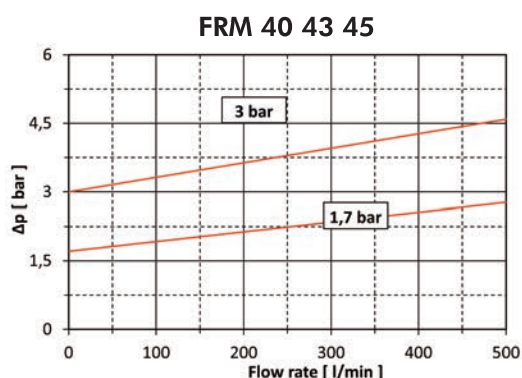

ACCESSORIES

These accessories fit all our standard models and must be ordered separately.



A EXTENSION TUBE

The flow from the filter must come out below the oil level to avoid possible generation of free air or foam. When necessary an extension tube can be fitted onto the knobs of the bowl end.

06.016.00267	ET2250	extension tube 250 mm long
06.016.00268	ET2500	extension tube 500 mm long

B CONNECTION TUBE

Connection tube is the necessary device between filter bowl and extension tubes (ET2250 / ET2500) and/or dif- fuser (DF040). Its plug and play option makes it easy to install and versatile.

06.016.00352	CT2250	connection tube 250 mm long
--------------	--------	-----------------------------

C DIFFUSER

Diffuser is an effective way to reduce foaming and turbulence normally caused by return lines. Plug and play option to be directly installed on the filter bowl or to connection tube (CT2250). Installation of a diffuser in the hydraulic tank is an easy way to ensure the reliability of the overall system. Diffuser must always be installed below the minimum oil level.

06.016.00361	DF040	diffuser Ø 40 mm
--------------	-------	------------------

USER TIPS FRM 40 43 45 B6B4B5



SPARE SEALS KIT (4)

	NBR	FKM
FRM 40 43 45 B6B4B5	06.021.00282	06.021.00283

COVER SCREWS TIGHTENING TORQUE (2)

M10	30 Nm
-----	-------

INDICATOR TIGHTENING TORQUE

10 Nm

WARNING

- ⚠ Make sure that Personal Protective Equipment (PPE) is worn during installation and maintenance operation.

DISPOSAL OF FILTER ELEMENT

- ⚠ The used filter elements and the filter parts dirty of oil are classified as "Dangerous waste material": they must be disposed according to the local laws by authorized Companies.

INSTALLATION

1. The filter head (8) must be properly positioned and well secured on the tank lid through the fixing holes.
2. The hose must be properly connected to the IN port.
- ⚠ 3. The OUT port must be clear (an extension tube could be fitted, if needed for having the outlet below the oil level).
4. Verify that no tension is present on the filter after mounting.
5. Enough space must be available for filter element replacement.
6. The visual clogging indicator must be in a easily viewable position.
7. When a electrical indicator is used, make sure that it is properly wired.
8. Keep in stock a spare FILTREC filter element for timely replacement when required.
9. Filter housing should be earthed.

OPERATION

- ⚠ 1. The filter must work within the operating conditions of pressure, temperature and compatibility given in the first page of this data sheet.
2. The filter element must be replaced as soon as the clogging indicator signals at working temperature.
3. If no clogging indicator is mounted, replace the element according to the system manufacturer's recommendations.

MAINTENANCE

- ⚠ 1. Before removing the top cover from the head, ensure that the system is switched off and there is no residual pressure in the filter.
2. Loosen the cover fixing bolts and rotate for element removal.
3. Remove the spring (3) first, then the dirty element (7) and the bowl (6).
4. Clean the bowl (6) and fit a new FILTREC element (7), verifying the part number, particularly concerning the micron rating.
5. When fitting the new element (7), open its plastic protection on the open end side and insert it onto the spigot in the filter bowl, then remove completely the plastic protection.
6. Check the top cover O-ring conditions and replace if necessary.
7. Put the spring (3) in its position on the filter element (7).
8. Mount the top cover onto the head and fix it screwing the fixing bolts.
- ⚠ 9. The used filter elements cannot be cleaned and re-used.

USER TIPS FRM 40 43 45 B7B5F6M

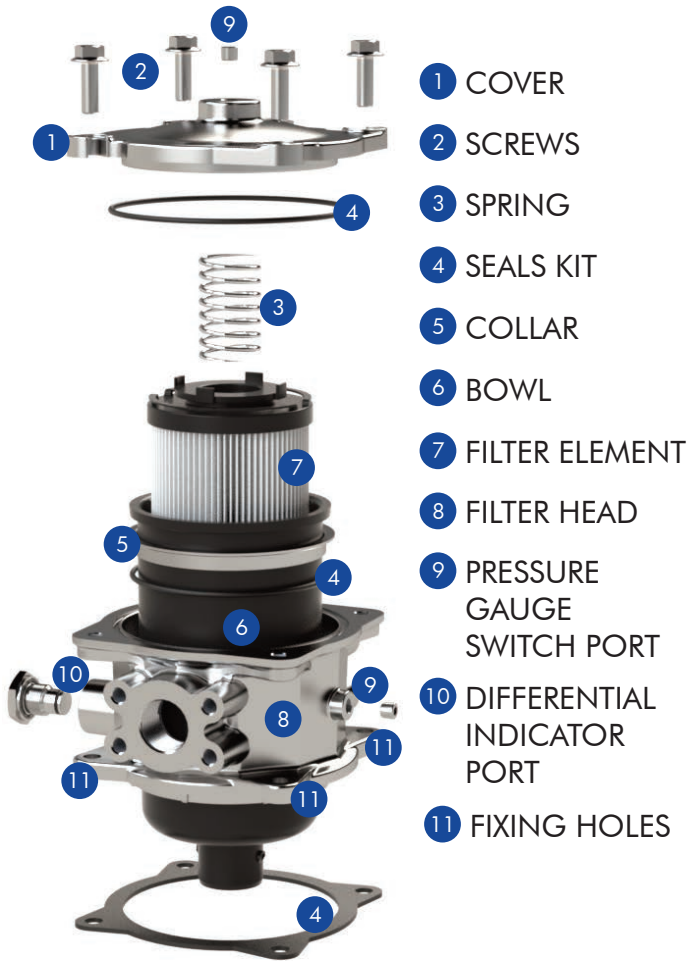

SPARE SEALS KIT (4)

	NBR	FKM
FRM 40 43 45 B7B5F6M	06.021.00439	06.021.00440

INDICATOR TIGHTENING TORQUE

PRESSURE GAUGE / SWITCH	10 Nm
DIFFERENTIAL	50 Nm

COVER SCREW TIGHTENING TORQUE (2)

M10	30 Nm
-----	-------

WARNING

- ⚠ Make sure that Personal Protective Equipment (PPE) is worn during installation and maintenance operation.

DISPOSAL OF FILTER ELEMENT

- ⚠ The used filter elements and the filter parts dirty of oil are classified as "Dangerous waste material": they must be disposed according to the local laws by authorized Companies.

INSTALLATION

- ⚠ 1. Make sure that all the filter components are properly mounted as per exploded view directions.
- 2. Enough space must be available for filter element replacement.
- 3. Keep in stock a spare FILTREC filter element for timely replacement when required.
- 4. Filter housing should be earthed.

OPERATION

- ⚠ 1. The filter must work within the operating conditions of pressure, temperature and compatibility given in the first page of this data sheet.
- 2. The filter element must be replaced as soon as the clogging indicator signals at working temperature.
- 3. If no clogging indicator is mounted, replace the element according to the system manufacturer's recommendations.

MAINTENANCE

- ⚠ 1. Before removing the top cover (1), ensure that the system is switched off and there is no residual pressure in the filter.
- 2. Remove the top cover (1).
- 3. Remove the spring (3) first, then the dirty element (7) and the bowl (6).
- 4. Clean the bowl (6) and fit a new FILTREC element (7), verifying the part number, particularly concerning the micron rating.
- 5. When fitting the new element (7), open its plastic protection on the open end side and insert it onto the spigot in the filter bowl, then remove completely the plastic protection.
- 6. Check the top cover O-ring conditions and replace if necessary.
- 7. Put the spring (3) in its position on the filter element (7).
- 8. Mount the top cover onto the head and fix it screwing the fixing bolts.
- ⚠ 9. The used filter elements cannot be cleaned and re-used.

