



FH420-XD SERIES THREADED

In line high pressure filters

In line filters for operating pressure up to 420 bar. Flow rate up to 500 l/min.
Elements according to DIN 24550



HOUSING	tested according to NFPA T3.10.5.1, ISO 10771, ISO 3968
PRESSURE:	Max operating: up to 420 bar Fatigue rating: 10 ⁶ cycles 0÷420 bar Burst: 1260 bar
CONNECTIONS:	G 1/2" ÷ G 1 1/2"
MATERIALS:	Head: cast iron Bowl: carbon steel Seal: NBR (FKM on request)
BYPASS VALVE:	6 bar ABF valve (on request) ABF valve+RF valve (on request)
ELEMENT	tested according to ISO 11170, 2941, 2942, 2943, 3724, 3968,16889, 16908, 23181
FILTER MEDIA:	Fibreglass: G01 - G03 - G06 - G10 G15 - G25
COLLAPSE PRESSURE:	21 bar 210 bar
TEMPERATURE RANGE:	with NBR seal from -30 °C to +100 °C with FKM seal (OPTION) from -25 °C to +120 °C
FLUID COMPATIBILITY:	Full with HH-HL-HM-HV HETG-HEES (acc. to ISO 6743/4). For use with other fluid please contact Filtrec Customer Service (info@filtrec.it).

OVERALL DIMENSIONS

FH420-XD-040-063-100

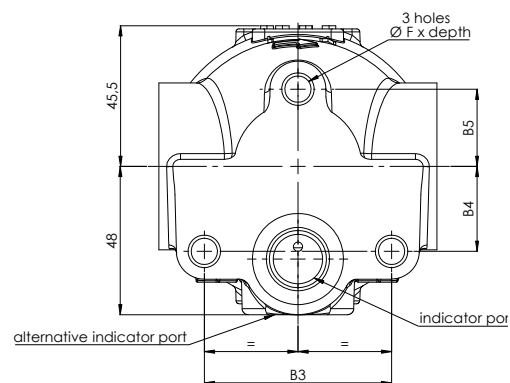
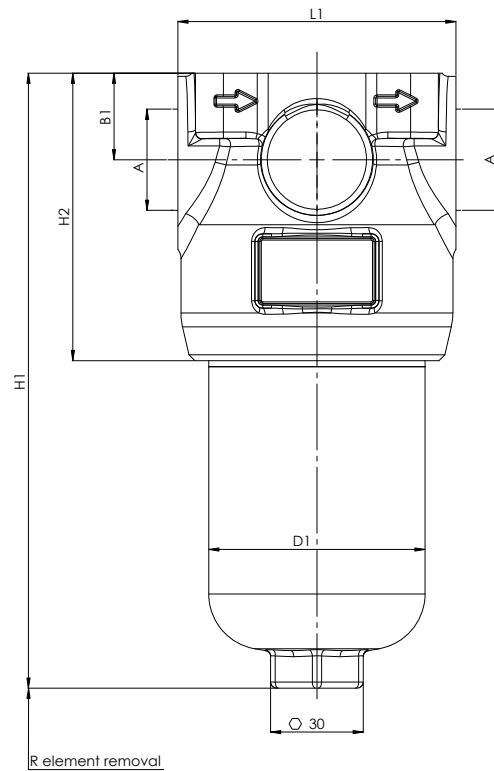

NOMINAL SIZE

MODEL	A	B1	B3	B4	B5	D1	F	H1	H2	L1	R	WEIGHT
FH420-XD040	G 1/2"							191				4,1 Kg
FH420-XD063	G 3/4"	28	60,6	27,5	25	70	M10x15	246	93	90	110	4,8 Kg
FH420-XD100	G 1"							340				5,9 Kg

OVERALL DIMENSIONS

FH420-XD-160-250-400

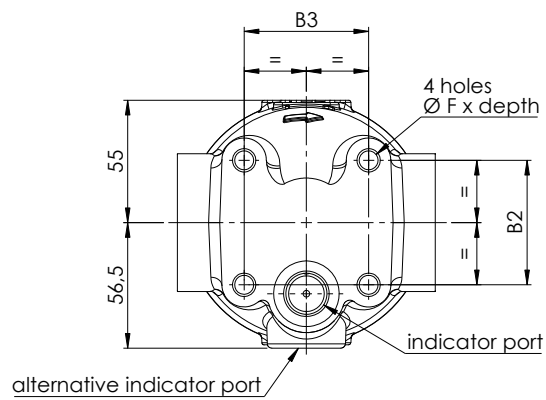
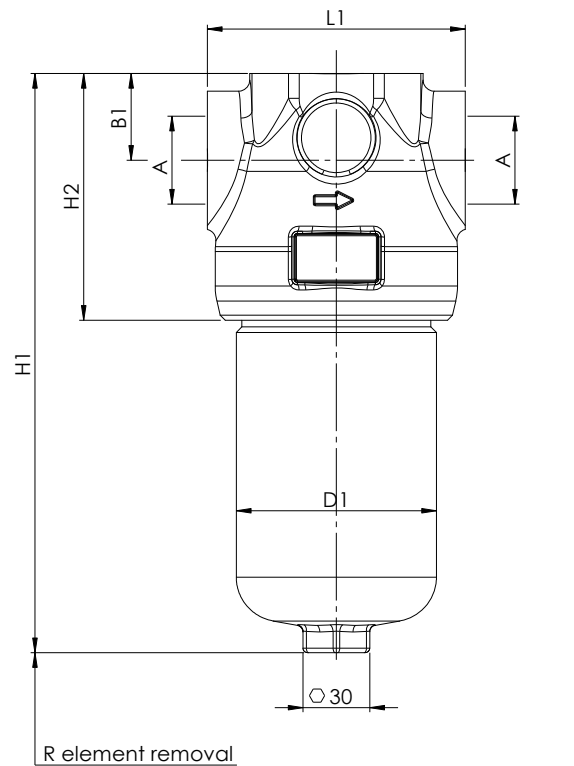

NOMINAL SIZE

MODEL	A	B1	B2	B3	D1	F	H1	H2	L1	R	WEIGHT
FH420-XD160	G 1 1/4"	47	76	64	110	M12x18	293,5	136	140	130	12,6 Kg
FH420-XD250	G 1 1/2"						384,5				13,7 Kg
FH420-XD400							533,5				18,1 Kg

ORDERING INFORMATION

	1.	2.	3.	4.	5.	6.	7.	8.	9.	10.	11.	12.	13.
	FH420	XD	160	G10	A	B	B4	D	C	W	000	S	0
SPARE ELEMENT	XD	160	G10	A									

1. FILTER SERIES	FH420	
2. FILTER ELEMENT SERIES	XD	
3. FILTER SIZE	040-063-100	
	160-250-400	
4. FILTER MEDIA	000	no element
	G01	glassfiber $\beta_{4\mu m(c)} \geq 1.000$
	G03	glassfiber $\beta_{5\mu m(c)} \geq 1.000$
	G06	glassfiber $\beta_{7\mu m(c)} \geq 1.000$
	G10	glassfiber $\beta_{12\mu m(c)} \geq 1.000$
	G15	glassfiber $\beta_{17\mu m(c)} \geq 1.000$
	G25	glassfiber $\beta_{22\mu m(c)} \geq 1.000$
5. ELEMENT COLLAPSE	A	21 bar
	Y	21 bar - with ABF / RF valve
	B	210 bar
	X	210 bar - with ABF / RF valve
6. SEALS	*B	NBR
	V	FKM (on request)
*omitted for spare element		
7. CONNECTIONS	B3	G 1/2"
	B4	G 3/4"
	B5	G 1"
	B6	G 1 1/4"
	B7	G 1 1/2"
For different thread options please check availability with Filtrec Customer Service.		for size 040 to 100
		for size 160 to 400
8. BYPASS VALVE	0	no by-pass
	D	6 bar
9. ABF VALVE / RF VALVE	0	no valve
	C	ABF valve (on request)
	R	ABF valve+ RF valve (on request)
ABF=anti back flow valve RF= reverse flow valve		
10. INDICATOR PORT OPTION	S	with metal plug
	W	with plastic plug
11. COMPULSORY FIELD	000	Filtrec standard
12. CORROSION PROTECTION	S	phosphated - standard
13. OPTION	0	standard
	D	drain plug (on request)
		standard on size 400

ORDERING INFORMATION

ACCESSORIES

The accessories must be ordered separately

11. INDICATOR

(F) digit for FKM seal option

*LC24=Led connector

For other options see clogging indicators catalogue

V05 (VF5)	differential visual 5 bar	
E05 (EF5)	differential electric 5 bar	
E05L (EF5L)	differential electric 5 bar + *LC24	
VEF5	differential visual and electric 5 bar	
V08 (VF8)	differential visual 8 bar	
E08 (EF8)	differential electric 8 bar	recommended for no by-pass option
E08L (EF8L)	differential electric 8 bar + *LC24	
VEF8	differential visual and electric 8 bar	

HYDRAULIC SYMBOLS

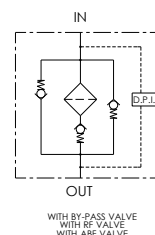
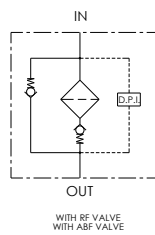
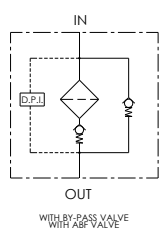
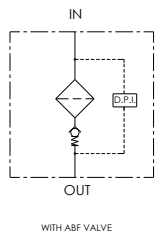
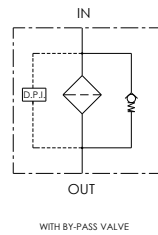
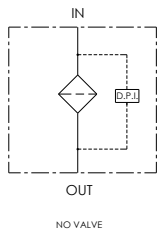

PRESSURE DROP (Δp) INFORMATION FOR FILTER SIZING

The total Delta P through a filter assembly is given from Housing Δp + Element Δp .

This ideally should not exceed 1,0 bar and should never exceed 1/3 of the set value of the by-pass valve. N.B. All the reported data have been obtained at our laboratory, according to specification ISO3968 with mineral oil having 32 cSt viscosity and density 0,875 Kg/dm³.

HOUSING PRESSURE DROP

The housing Δp is given by the curve of the considered model and port, in correspondence of the flow rate value.

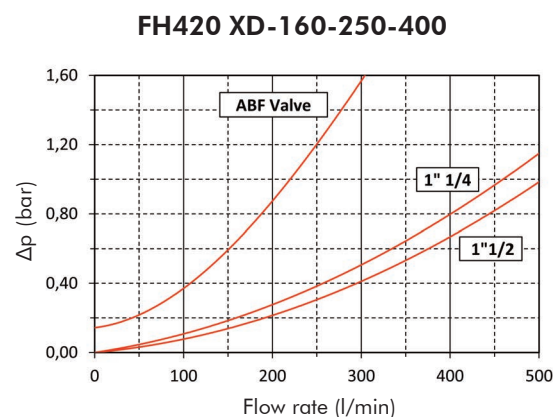
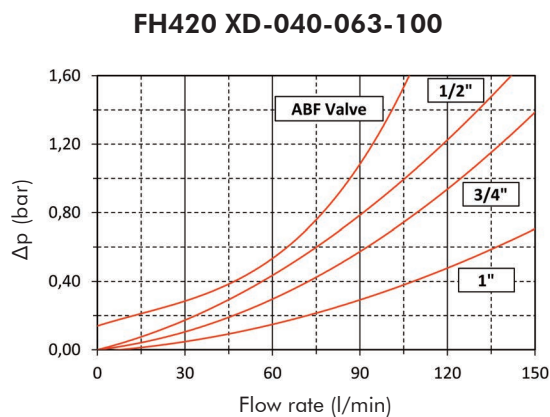

ELEMENT PRESSURE DROP (filter elements 21 bar collapse)

The element Δp (bar) is given by the flow rate (l/min) multiplied by the factor in the table here below corresponding to the selected media and divided by 1000.

If the oil has a viscosity V_x different than 32 cSt a corrective factor $V_x/32$ must be applied.

Example: 80 l/min with XD160G10A and oil viscosity 46 cSt $> (80 \times 2,63)/1000 \times (46/32) = 0,30$ bar

	G01	G03	G06	G10	G15	G25
XD040	22,00	15,40	13,5	7,88	6,75	5,63
XD063	16,15	11,31	9,00	5,54	4,85	4,15
XD100	12,00	8,40	5,85	3,60	3,15	2,70
XD160	7,81	5,47	4,47	2,63	1,84	1,49
XD250	5,20	3,64	2,61	1,68	0,91	0,86
XD400	3,25	2,28	1,52	1,12	0,64	0,57

EXAMPLE OF TOTAL Δp CALCULATION

FH420XD160G10ABB4DCW000S0 with 80 l/min and oil 46 cSt:

Housing Δp 0,25 bar + element Δp 0,30 bar $(80 \times 2,63)/1000 \times (46/32) =$ total assembly Δp 0,55 bar

ELEMENT PRESSURE DROP (filter elements 210 bar collapse)

The element Δp (bar) is given by the flow rate (l/min) multiplied by the factor in the table here below corresponding to the selected media and divided by 1000.

If the oil has a viscosity V_x different than 32 cSt a corrective factor $V_x/32$ must be applied.

Example: 80 l/min with XD160G10B and oil viscosity 46 cSt $> (80 \times 3,37)/1000 \times (46/32) = 0,39$ bar

	G01	G03	G06	G10	G15	G25
XD040	34,97	24,48	22,50	14,63	12,38	10,13
XD063	29,23	20,46	16,62	10,38	8,65	6,92
XD100	19,00	13,30	10,35	6,75	5,85	4,95
XD160	8,13	5,69	4,74	3,37	2,81	2,25
XD250	5,40	3,78	3,06	2,52	2,16	1,80
XD400	3,38	2,36	1,94	1,57	1,29	1,01

EXAMPLE OF TOTAL Δp CALCULATION

FH420XD160G10BBB4DCW000S0 with 80 l/min and oil 46 cSt :

Housing Δp 0,25 bar + element Δp 0,39 bar $(80 \times 3,37)/1000 \times (46/32) =$ total assembly Δp 0,64 bar

BYPASS VALVE PRESSURE DROP

The bypass valve Δp is given by the curve of the considered model and setting, in correspondence of the flow rate value.

FH420 XD040-063-100

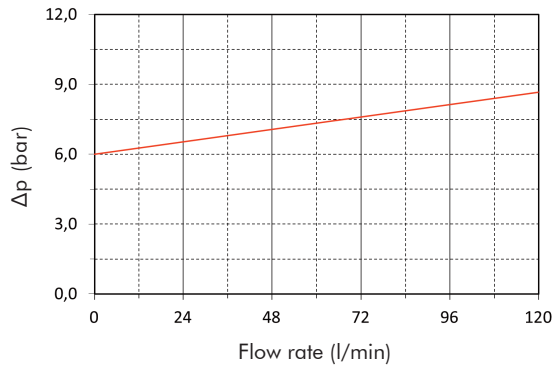

FH420 – XD160-250-400

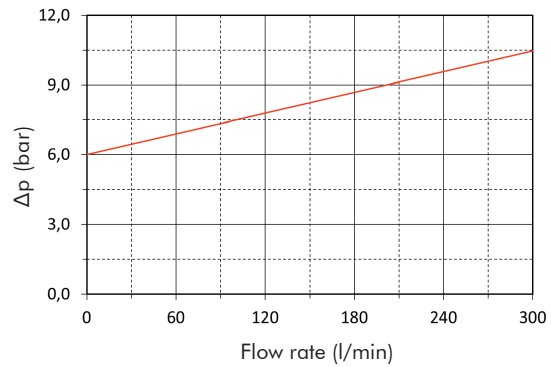

RF VALVE PRESSURE DROP

FH420 XD040-063-100

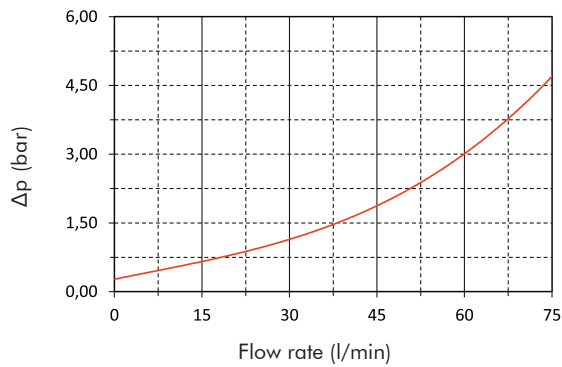

FH420 XD160-250-400

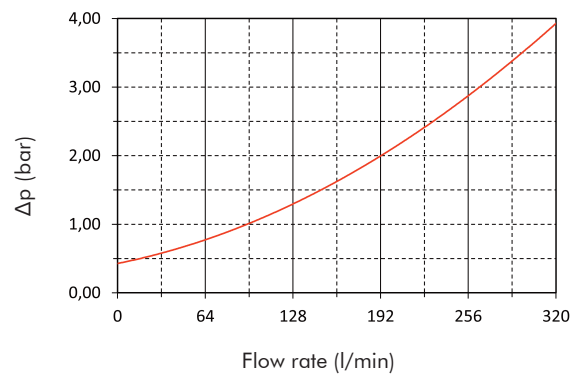

N.B. All the reported data have been obtained at our laboratory, according to specification ISO3968 with mineral oil having 32 cSt viscosity and density 0,875 Kg/dm³.

USER TIPS



- 1 FILTER HEAD
- 2 INDICATOR PORT
- 3 FIXING HOLES
- 4 FILTER ELEMENT
- 5 SEAL KIT
- 6 FILTER BOWL
- 7 IDENTIFICATION LABEL
- 8 DRAIN PLUG
- 9 INDICATOR PLUG

INDICATOR TIGHTENING TORQUE

90 Nm

SPARE SEAL KIT PART NUMBER (5)

	NBR	FKM
FH420 XD 040-060-100	06.021.00268	06.021.00269
FH420 XD 160-250-400	06.021.00272	06.021.00273

BOWL TIGHTENING TORQUE

screw up filter bowl till end

WARNING

- ⚠ Make sure that Personal Protective Equipment (PPE) is worn during installation and maintenance operation.

DISPOSAL OF FILTER ELEMENT

- ⚠ The used filter elements and the filter parts dirty of oil are classified as "Dangerous waste material": they must be disposed according to the local laws by authorized Companies.

INSTALLATION

- ⚠ 1. The IN and OUT ports must be connected to the hoses in the correct flow direction an arrow shows on the filter head (1).
- 2. The filter housing should be preferably mounted with the bowl (6) downward.
- 3. Secure to the frame the filter head (1) using the threaded fixing holes (3).
- 4. Verify that no tension is present on the filter after mounting.
- 5. Enough space must be available for filter element replacement.
- 6. The visual clogging indicator must be in a easily viewable position.
- 7. When a electrical indicator is used, make sure that it is properly wired.
- ⚠ 8. Never run the system with no filter element fitted.
- 9. Keep in stock a spare FILTREC filter element for timely replacement when required.
- 10. Filter housing should be earthed.

OPERATION

- ⚠ 1. The filter must work within the operating conditions of pressure, temperature and compatibility given in the first page of this data sheet.
- 2. The filter element must be replaced as soon as the clogging indicator signals at working temperature (in cold start conditions, oil temperature lower than 30°C, a false alarm can be given due to oil viscosity).
- 3. If no clogging indicator is mounted, replace the element according to the system manufacturer's recommendations.

MAINTENANCE

- ⚠ 1. Make sure that the system is switched off and there is no residual pressure in the filter.
- 2. Unscrew the bowl (6) by turning it anti-clockwise and remove it.
- 3. Remove the dirty element (4).
- 4. Fit a new FILTREC element (4), verifying the part number, particularly concerning the micron rating; open its plastic protection on the open end side and insert it onto the spigot in the filter head, then remove completely the plastic protection.
- 5. Clean carefully the bowl; check the O-rings (5) conditions and replace if necessary.
- 6. Lubricate the bowl's thread (6) and screw it by hand in the filter head (1) by turning it clockwise.
- 7. Screw in the bowl to stop.
- ⚠ 8. The used filter elements cannot be cleaned and re-used.

